

DIGITAL SOUND FIELD PROCESSOR DSP-E300

SERVICE MANUAL

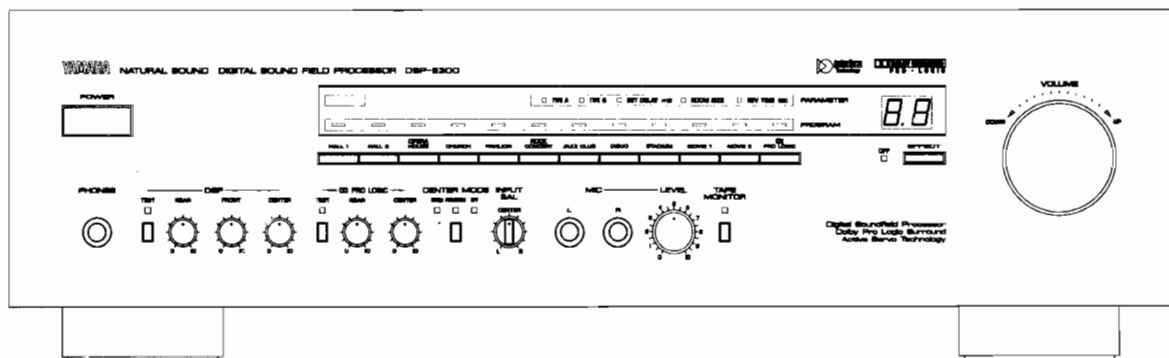

IMPORTANT NOTICE

This manual has been provided for the use of authorized YAMAHA Retailers and their service personnel. It has been assumed that basic service procedures inherent to the industry, and more specifically YAMAHA Products, are already known and understood by the users, and have therefore not been restated.

WARNING: Failure to follow appropriate service and safety procedures when servicing this product may result in personal injury, destruction of expensive components and failure of the product to perform as specified. For these reasons, we advise all YAMAHA product owners that all service required should be performed by an authorized YAMAHA Retailer or the appointed service representative.

IMPORTANT: The presentation or sale of this manual to any individual or firm does not constitute authorization, certification or recognition of any applicable technical capabilities, or establish a principle-agent relationship of any form.

The data provided is believed to be accurate and applicable to the unit(s) indicated on the cover. The research, engineering, and service departments of YAMAHA are continually striving to improve YAMAHA products. Modifications are, therefore, inevitable and specifications are subject to change without notice or obligation to retrofit. Should any discrepancy appear to exist, please contact the distributor's Service Division.

WARNING: Static discharges can destroy expensive components. Discharge any static electricity your body may have accumulated by grounding yourself to the ground buss in the unit (heavy gauge black wires connect to this buss).

IMPORTANT: Turn the unit OFF during disassembly and parts replacement. Recheck all work before you apply power to the unit.

■ CONTENTS

TO SERVICE PERSONNEL	1	BLOCK DIAGRAM	16~17
SPECIFICATIONS	1	INTERCONNECT WIRING DIAGRAM	18~19
REAR PANELS	2	SCHEMATIC DIAGRAM	20~27
INTERNAL VIEW	3	PRINTED CIRCUIT BOARD	28~53
DISASSEMBLY PROCEDURES	3	PARTS LIST	54~64
TEST PROGRAM	4~5	REMOTE CONTROL TRANSMITTER	65
IC DATA	5~15		

■ TO SERVICE PERSONNEL

- Critical Components Information.**
Components having special characteristics are marked and must be replaced with parts having specifications equal to those originally installed.
- Leakage Current Measurement (For 120V Model Only).**
When service has been completed, it is imperative that you verify that all exposed conductive surfaces are properly insulated from supply circuits.
 - Meter impedance should be equivalent to 1500 ohm shunted by 0.15μF.
 - Leakage current must not exceed 0.5mA.
 - Be sure to test for leakage with the AC plug in both polarities.

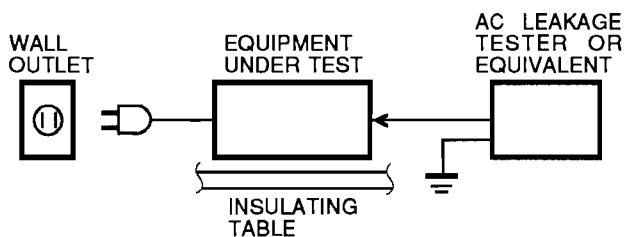

- **POLARIZATION (U, C models only)**
This processor product is equipped with a polarized alternating-current line plug (a plug having one blade wider than the other). This plug will fit into the power outlet only one way. This is a safety feature.

■ SPECIFICATIONS

■ EFFECT POWER AMP SECTION

- **Minimum RMS Output Power Per Channel**
(YST switch off) 1kHz, 1%, 6Ω 15W

■ PROCESSOR SECTION

- **A/D Converter**
Resolution 16 bit linear
Features 2 ch A/D, 18-bit calibration
- **D/A Converter**
Resolution 16 bit linear
- **Preset Programs**
DSP Sound Field Programs 11 programs, 20 subprograms

Dolby Pro Logic Surround
- **Input Sensitivity/Input Impedance**
INPUT, TAPE PB 150mv / 47kΩ
MIC 500μV/5.6kΩ
- **Frequency Response (20Hz—20kHz)**
MAIN OUT 0±1dB

■ GENERAL

- **Power Requirements**
U. S. & Canada AC 120V, 60Hz
General AC 110/120/220/240V, 50/60Hz
U.K., Australia AC 240V, 50Hz
Europe AC 220V, 50Hz
- **Power Consumption**
U. S. & Canada 170W
Other Areas 110W
- **AC Outlets (U. S., Canada, General models only)**
SWITCHED x 2 100W max.
UNSWITCHED x 1 200W max.
- **Dimensions (WxHxD)** 435x130x375.4mm
(17-1/8"x5-1/8"x14-3/4")
- **Weight** 10kg
(22 lb)

*Specifications are subject to change without notice.

- U U. S. A. model
- C Canadian model
- B British model
- A Australian model
- G European model
- R General model

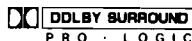

Manufactured under license from Dolby Laboratories Licensing Corporation. Additionally licensed under one or more of the following patents: U. S. numbers 3682, 886, 3746, 792, and 3959, 590; Canada numbers 1004, 603 and 1037, 877. "Dolby" and the double-D symbol are trademarks of Dolby Laboratories Licensing Corporation.

● DIMENSIONS

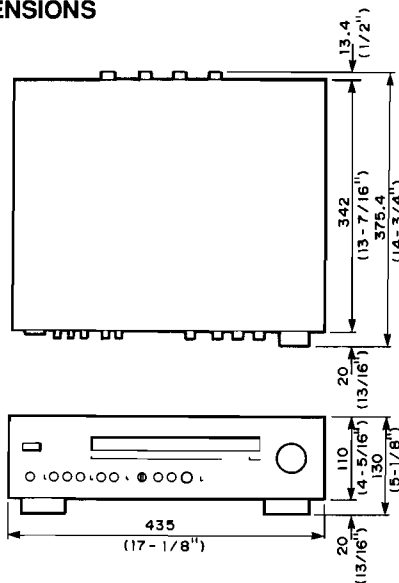

Unit : mm (inch)

REAR PANELS

U. C model

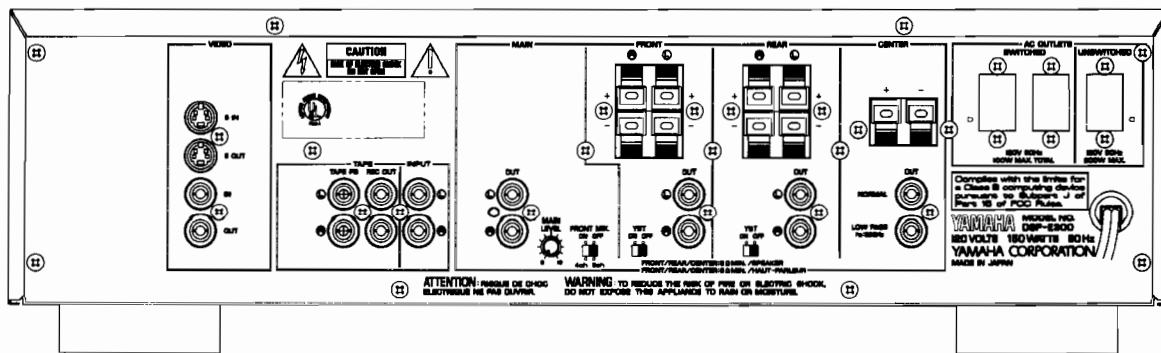

R model

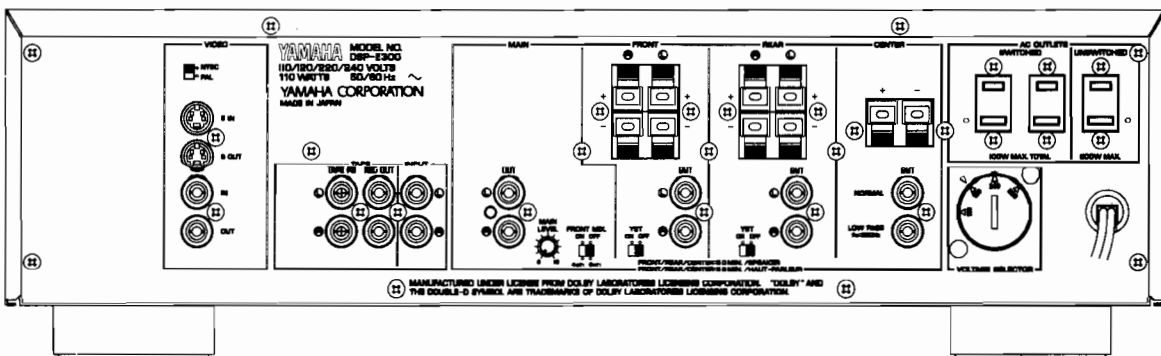

A, B models

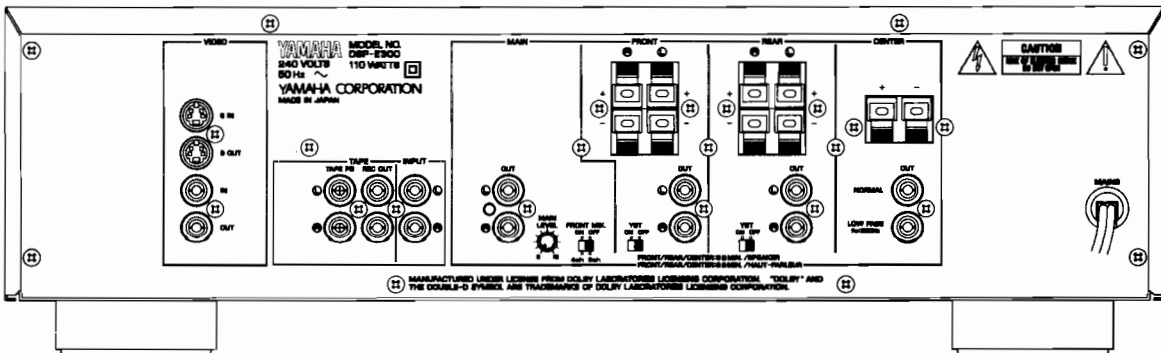

G model

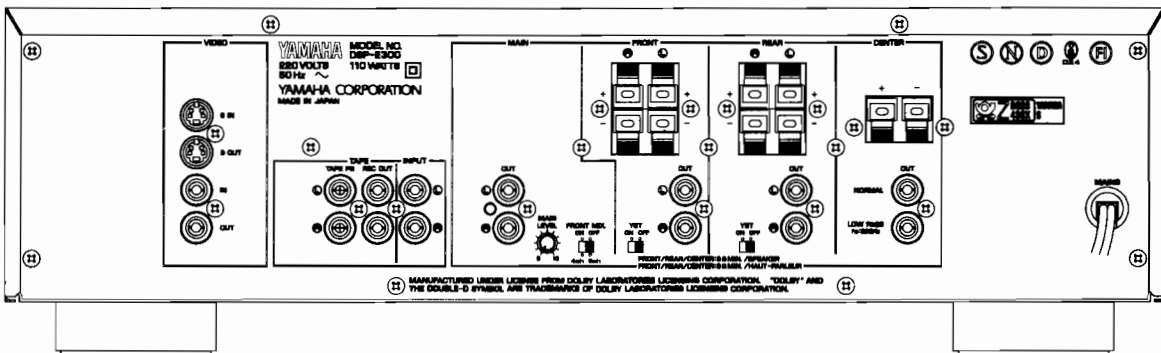

■ INTERNAL VIEW

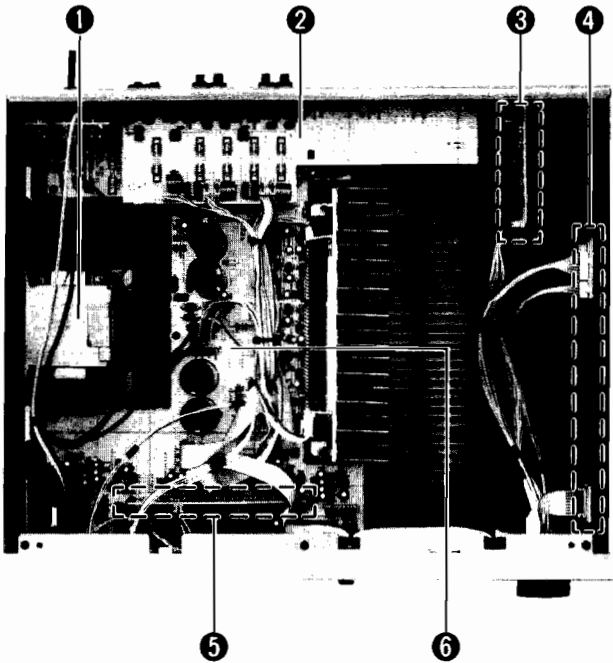

- ① POWER TRANSFORMER
 U model : XG782B00
 R model : XG783B00
 A, B models : XG784B00
 G model : XG785B00
 C model : XH153B00
- ② OPERATION CIRCUIT BOARD (3)
- ③ EFFECT AMP CIRCUIT BOARD (4) : S-VIDEO SECTION
- ④ OPERATION CIRCUIT BOARD (2) : DSP SECTION
- ⑤ OPERATION CIRCUIT BOARD (4) : DOLBY PRO-LOGIC SECTION
- ⑥ EFFECT AMP CIRCUIT BOARD (1)

■ DISASSEMBLY PROCEDURES

(Remove parts in disassembly order as numbered.)

1. Removal of Top Cover

- a. Remove 4 screws (①) and 2 screws (②) in Fig. 1.
- b. Lift the Top Cover to the back side and move it rearward slantingly.

2. Removal of Bottom Cover

Remove 10 screws (③) in Fig. 1.

3. Removal of Operation Circuit Board (2)

Remove 4 screws (④) in Fig. 1.

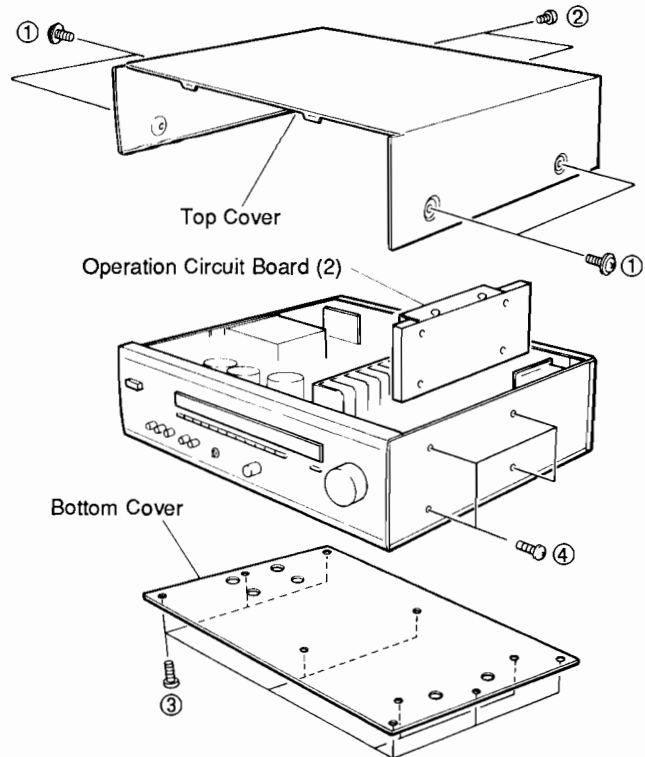

Fig. 1

■ TEST PROGRAM

The DSP-E300 has a self-diagnosis function performed by using internal test programs. Be sure to verify all test programs.

● Starting Test Program

While holding down 3 program keys (HALL 1, HALL 2 and OPERA HOUSE) simultaneously, turn on the POWER switch.

Content of Test Program

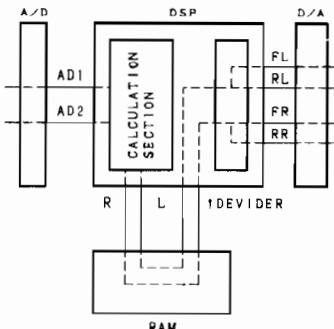
Program	Item	Operation	Program	Item	Operation
No. 1 (HALL 1)	EXIT DIAG	Sets back to the normal operation mode from the test program mode.	No.7 (JAZZ-CLUB)	RAM THROUGH	1. Sets to the RAM THROUGH mode.  As A/D input is in 2 channels, (L+R) /2 and (L-R), calculation done inside the DSP according to this program is as follows. Supposing $AD1=(L+R) /2$ and $AD2=L-R$, $FL, RL=AD1+AD 2/2=$ $(L+R) /2+(L-R) /2=L$ $FR, RR=AD1-AD 2/2=$ $(L+R) /2-(L-R) /2=R$
No. 2 (HALL 2)	TEST LED-1	1.LEDs light in the following order. 7seg LED 0.0 1 1 2.2 3 3 4.4 5 5 6.6 7 7 8.8 9 9 HALL 1 HALL 2 OPERA HOUSE CHURCH PAVILION ROCK CONCERT JAZZ CLUB DISCO STADIUM MOVIE 1 MOVIE 2 PRO LOGIC TYPE A TYPE B INIT DELAY ROOM SIZE REV TIME DSP TEST PRO LOGIC TEST NORMAL PHANTOM OFF TAPE MONITOR EFFECT OFF 2. Finally, all LEDs other than 7seg LED light and then the 7seg LED indicates "2".		L OUT R OUT	
No.3 (OPERA-HOUSE)	TEST LED-2	All 7seg LEDs light. LEDs from HALL 1 to PRO LOGIC all light. LEDs from TYPE A to REV TIME all light. LEDs from DSP TEST to EFFECT OFF all light.	No.8 (DISCO)	DSP THROUGH	2. The 7seg LED indicates "8".

Program	Item	Operation
No.9 (STADIUM)	RAM THROUGH (L+R) /2 OUT	<p>1. Sets to the RAM THROUGH mode.</p> <p>FL, RL=AD1=(L+R) /2 FR, RR=AD1=(L+R) /2</p> <p>2. The 7seg LED indicates "9".</p>

IC DATA

IC2 : M50747-B87
8bit μ -COM

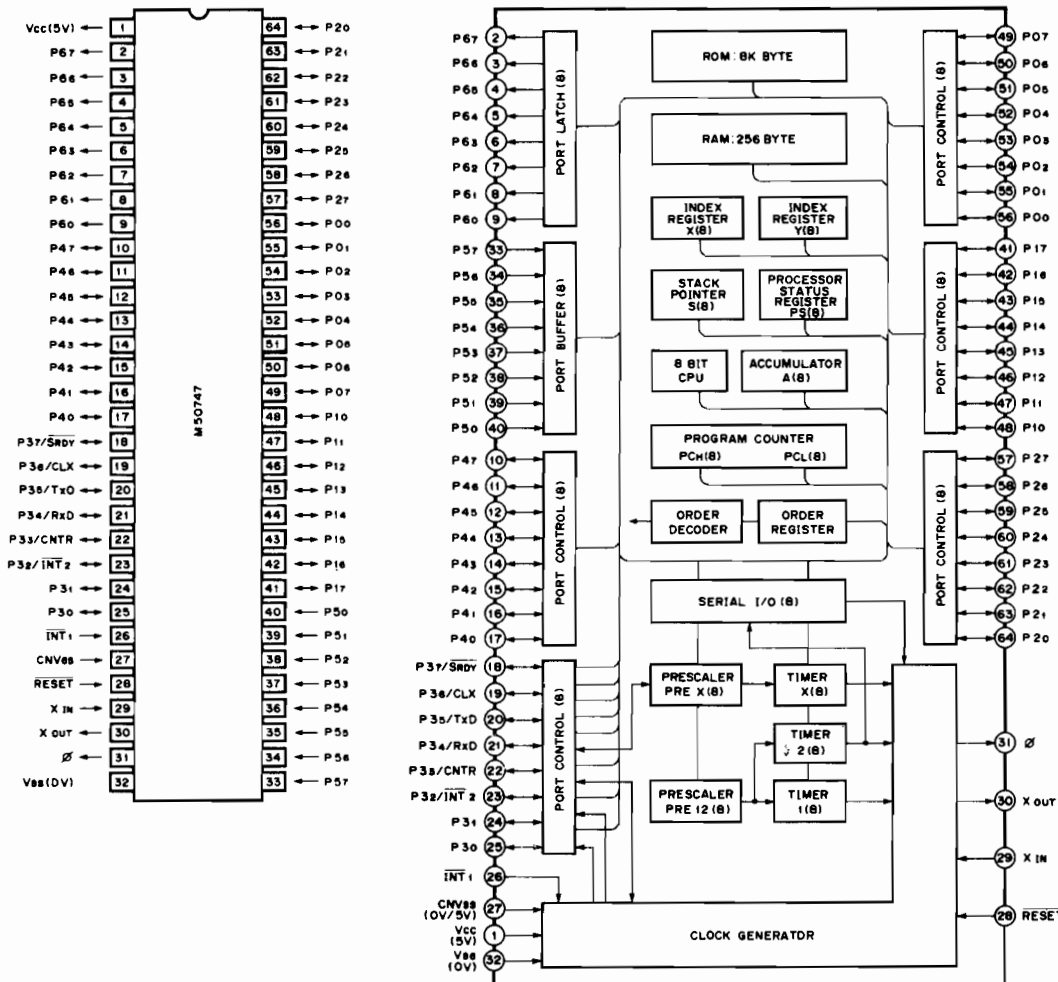

Pin No.	Pin name	Function Name	I/O	Active	Description
1	Vcc	VDD	—		+5V
2	P67	SH	O	H	LED segment
3	P66	SG	O	H	
4	P65	SF	O	H	
5	P64	SE	O	H	
6	P63	SD	O	H	
7	P62	SC	O	H	
8	P61	SB	O	H	
9	P60	SA	O	H	
10	P47	DA7	O	L/H	Digital signal for VCA control (When DA0 (LSB) to DA7 (MSB) are all "L", VCA is - When ATTs are all "H", VCA is 0dB.)
11	P46	DA6	O	L/H	
12	P45	DA5	O	L/H	
13	P44	DA4	O	L/H	
14	P43	DA3	O	L/H	
15	P42	DA2	O	L/H	
16	P41	DA1	O	L/H	
17	P40	DA0	O	L/H	
18	P37/SRDY	X	O	—	Unused
19	P36/CLK	CLK1	I		Clock data for serial transmission of the superimpose IC.
20	P35/TXD	SO	O		
21	P34/RXD	CLK0	O		
22	P33/CNTR	CE	O	L	Chip select of the superimpose IC
23	P32/INT2	SY DET	I	L/H	Picture detect (External picture input available at "H")
24	P31	N/P	I	L	PAL/NTSC select (NTSC at "L")
25	P30	REM IN	I		Remote control beam reception signal input
26	INT1	REM IN	—		
27	CNVSS	CN V _{ss}	—		GND
28	RESET	RESM	—		Reset
29	X IN	OSC1	—		Clock(8MHz)
30	X OUT	OSC0	—		
31	φ	φ	—		Unused
32	V _{ss}	V _{ss}	I		GND
33	P57	PDET	I	L/H	Power ON/OFF detect (OFF at "L")
34	P56	X	I		Unused
35	P55	ENCB	I		Rotary encoder input
36	P54	ENCA	I		
37	P53	K3	I	H	Key input (Key input available at "H")
38	P52	K2	I	H	
39	P51	K1	I	H	
40	P50	K0	I	H	
41	P17	D4	O	H	Digit line
42	P16	D3	O	H	
43	P15	D2	O	H	
44	P14	D1	O	H	
45	P13	D0	O	H	
46	P12	CMT	O	H	Center
47	P11	EMT	O	L	Effect mute signal
48	P10	MMT	O	H	Main
49	P07	CMD	O	L/H	DOLBY center mode select (Normal at "H")
50	P06	CCH	O	L/H	DOLBY center channel select (OFF at "H")
51	P05	DBY	O	L/H	DOLBY select (ON at "H")
52	P04	RES	—		
53	P03	TAPE	O	L/H	TAPE MONITOR select (Tape monitor ON at "H")
54	P02	CE1	O		Chip select of input select IC
55	P01	DACS	O		Unused
56	P00	DSPTS	O		Interface with HD63BOIY
57	P27	DSP7	O		
58	P26	DSP6	O		
59	P25	DSP5	O		
60	P24	DSP4	O		
61	P23	DSP3	O		
62	P22	DSP2	O		
63	P21	DSP1	O		
64	P20	DSP0	O		

IC27 : HD63B01YORL37P
8bit μ -COM

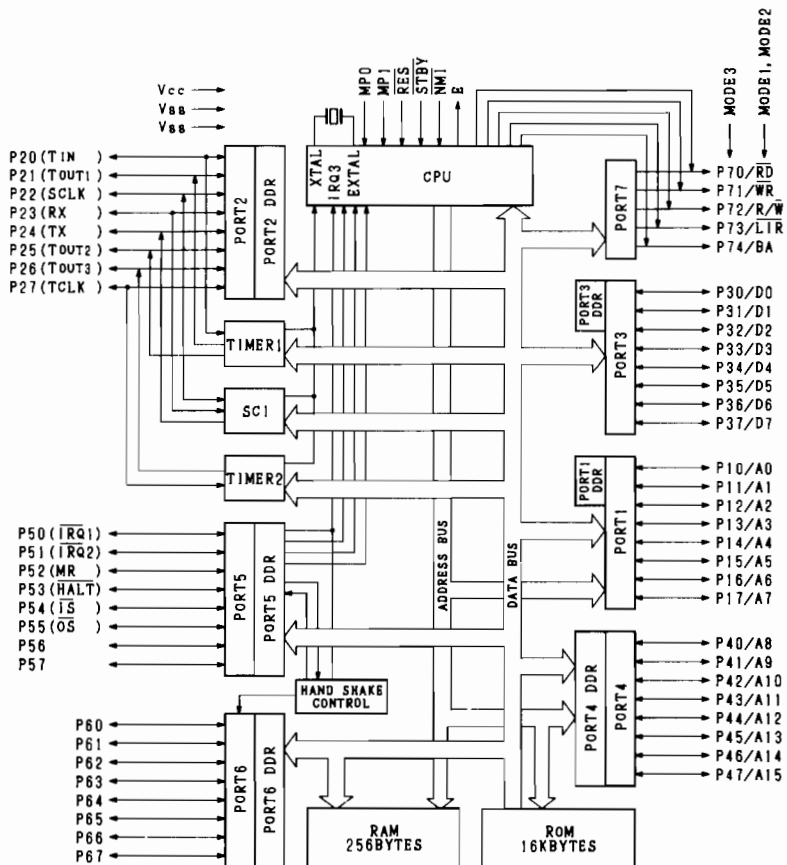
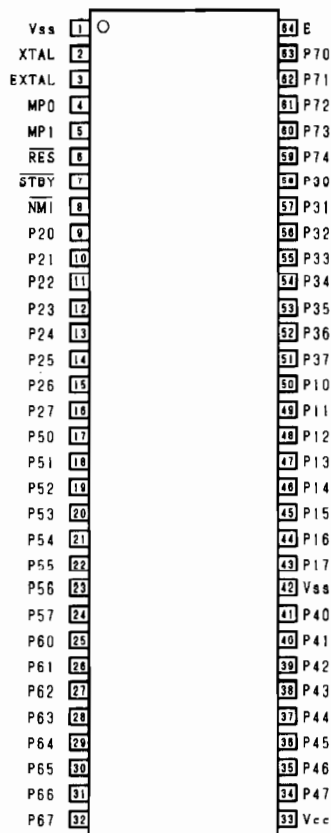

Pin No.	Pin name	Function Name	I/O	Description
1	Vss	Vss	—	GND
2	XTAL	XTAL	—	Unused
3	EXTAL	EXTAL	I	Clock input
4	MP0	MP0	I	"H" mode setting (with single chip mode fixed)
5	MP1	MP1	I	
6	RES	REX	I	Reset input
7	STBY	STBY	I	"H" unused
8	NMI	NMI	I	
9	P20		O	Output port (unused)
10	P21		O	
11	P22	SCLK	O	Clock for transmitting serial data to DSP
12	P23	RX	I	Serial data input port (unused)
13	P24	TX	O	Serial data output port to DSP
14	P25		O	Output port (unused)
15	P26		O	
16	P27		O	
17	P50		I	"L" unused
18	P51		I	
19	P52		I	
20	P53		I	Command format select ("H")
21	P54	DSPS	I	Command input strobe signal
22	P55		I	"L" unused
23	P56	CRS	O	DSP serial data input reset
24	P57	DBY	O	Output port (unused)
25	P60	DSP0	I	Command input port
26	P61	DSP1	I	
27	P62	DSP2	I	
28	P63	DSP3	I	
29	P64	DSP4	I	
30	P65	DSP5	I	
31	P66	DSP6	I	
32	P67	DSP7	I	+5V
33	Vcc	Vcc	—	Output port (unused)
34	P47		O	
35	P46		O	
36	P45		O	
37	P45		O	
38	P43		O	
39	P42		O	
40	P41		O	
41	P40		O	
42	Vss	Vss	—	GND
43	P17		O	Output port (unused)
44	P16		O	
45	P15		O	
46	P14		O	
47	P13		O	
48	P12		O	
49	P11		O	
50	P10		O	
51	P37		O	
52	P36		O	
53	P35		O	
54	P34		O	
55	P33		O	
56	P32		O	
57	P31		O	
58	P30		O	
59	P74	BA	O	
60	P73	LIR	O	
61	P72	R/W	O	
62	P71	WR	O	
63	P70	RD	O	
64	WE	E	O	

IC703 : M50455-060SP
Supper Impose

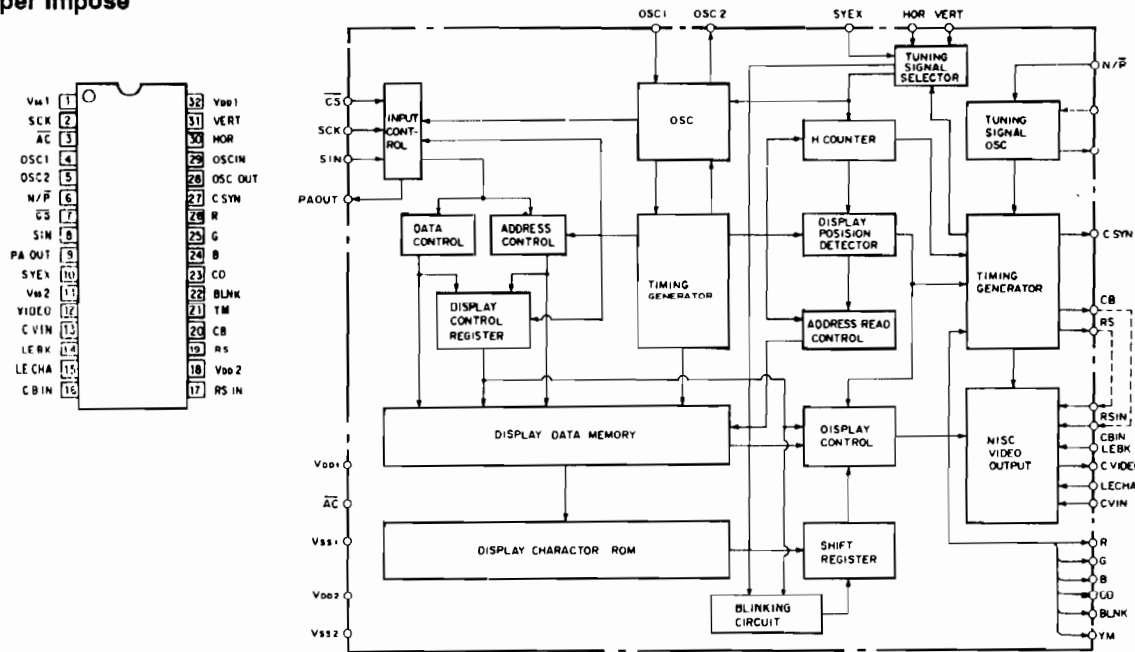

Pin No.	Pin Name	Pin Description	Function
1	VSS 1	Earth terminal	Connect with GND by digital system earth terminal.
2	SCX	Serial clock input	When it is SC terminal "L", serial data of S IN is taken in with the start-up of SCK. Hysteresis input.
3	AC	Automatic clear input	Reset IC internal circuit with "L" status. Pull-up resistance has been contained. Hysteresis input.
4	OSC 1	Oscillation circuit external terminal	External terminal for oscillation circuit for indication use. The standard oscillation frequency is about 7MHz.
5	OSC 2		Display position toward horizontal direction of TV picture and letter width are determined by the oscillation frequency.
6	N/P	NISC/PAL switching input	It is NTSC or PAL system synchronized signal generation switching terminal.
7	CS	Chip selection input	Chip selection terminal. When serial data transfer is conducted, the chip selection terminal shall be "L" status.
8	S IN	Serial data input	Data and address of memory for use in the display resistor and display data are input by serial.
9	PA OUT	Parity output	It is odd number parity output, and it will detect 1 bit mistake in a word of S IN.
10	SYEX	Synchronized signal changeover input	Externally synchronized or internally synchronized signal switching terminal. Under "H" status, it becomes externally synchronized signal mode, and with "L" status, it becomes internally synchronized signal mode. SYEX composes or of priority of internal synchronization and EX. Resistor of address 243 in the display control resistor. Pull-up resistance is contained.
11	VSS 1	Earth terminal	Connect with GND by analog earth terminal.
12	VIDEO	Composite video output	It is composite video signal output terminal. Composite video signal of 2Vp-p is output. When it is super imposition, it will output increasing the volume of letter output to CV IN signal.
13	CV IN	Composite video input	It is composite video signal input terminal. When it is super impose, letter output etc. Will be increases for the composite video signal.
14	LEBK	Blanking level	It is input terminal to determine blanking level of video signal.
15	LECHA	Character level input	It is input terminal to determine the letter output level in the video signal. Color of letter is white.
16	CB IN	Color burst input	It will input transforming CB output to color burst level by external circuit.

DSP-E300

Pin No.	Pin Name	Pin Description	Function
17	RS IN	Lettering background carrier color signal input	Input is done transforming RS output to carrier color signal level of video signal by external circuit.
18	VDD 2	Power source terminal	Connect with +5V by analog system power source terminal.
19	RS	Lettering background carrier color signal output	It is carrier color signal output for the coloring background. It will output signal having phase angle for the color burst signal CB. Amplitude : 5V.
20	CB	Color burst output	When it is NTSC system, it will output color burst of 3.58MHz and 4.43MHz when it is PAL system. Amplitude : 5V.
21	YM	Brightness signal output	It is brightness signal output. Polarity selection can be done when lettering type ROM is determined.
22	BLNK	Lettering background output	It will output lettering background signal. POLarity selection can be done when lettering type ROM is decided.
23	CO	Lettering type output	Lettering type signal is output. POLarity selection can be done when lettering type is determined.
24	B	Blue output	It is blue output terminal. Polarity selection can be done when lettering type ROM is determined.
25	G	Green output	It is green output terminal. Polarity selection can be done when lettering type ROM is determined.
26	R	Red output	It is red output terminal. Polarity selection can be done when lettering type ROM is determined.
27	CSYN	Composite burst output	NTSC or PAL system composite burst is output. Polarity is negative polarity, and amplitude is 5V.
28	OSC OUT	Oscillation circuit for burst generation	It is external terminal of oscillation circuit for the generation of burst. When it is NTSC system, it is 14.32MHz.
29	OSC IN		When it is PAL system, oscillation frequency of 17.73MHz is used.
30	HOR	Horizontal burst	Horizontal burst is output. Histeresis input. Polarity selection can be done when lettering type ROM is determined.
31	VERT	Vertical burst	Vertical burst is input. Histeresis input. Polarity selection can be done when lettering type ROM is determined.
32	VDD2	Power source terminal	Connect with +5V by digital power source terminal.

IC28 : YM3413
LDSP

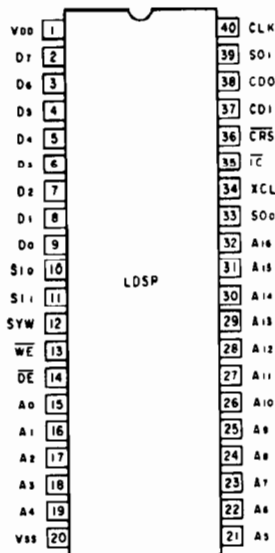

Pin No.	Pin Name	I/O	Function	Pin No.	Pin Name	I/O	Function
1	VDD	—	+5V Voltage Supply	40	CLK	I	Master clock input
2	D7	I/O	I/O pins connected to memory data bus (8 bit)	39	SO1	O	Serial data output
3	D6	I/O		38	CD0	O	CD data output
4	D5	I/O		37	CD1	I	CD data input
5	D4	I/O		36	CRS	I	CD data sync signal input
6	D3	I/O		35	IC	I	LDSP initial clear signal input
7	D2	I/O		34	XCLK	I	ACIA clock input
8	D1	I/O		33	SD0	O	Serial data output
9	D0	I/O		32	A16	O	Outputs connected to
10	SI0	I	31	A15	O		
11	SI1	I	30	A14	O		
12	SYW	I	29	A13	O		
13	WE	O	28	A12	O		
14	OE	O	27	A11	O		
15	A0	O	26	A10	O		
16	A1	O	25	A9	O		
17	A2	O	24	A8	O		
18	A3	O	23	A7	O		
19	A4	O	22	A6	O		
20	VSS	O	GND	21	A5	O	

IC26 : YM3422
Digital Signal Format Converter

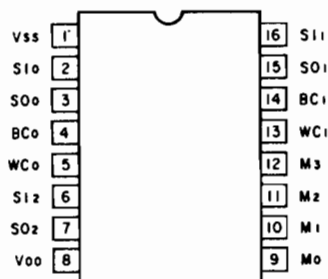

Pin No.	Pin Name	I/O	Function
1	VSS	—	GND terminal
2	SI0	IN	Serial data input (ch 0)
3	SO0	OUT	Serial data output (ch 0)
4	BC0	IN	Bit clock input
5	WC0	IN	System synchronized signal input
6	SI2	IN	Serial data input (ch 0)
7	SO2	OUT	Serial data output (ch 0)
8	VDD	—	Voltage supply (+5V)
9	M0	IN	Mode select signal
10	M1	IN	Mode select signal
11	M2	IN	Mode select signal
12	M3	IN	Mode select signal
13	WC1	IN	System synchronized signal input (Word clock)
14	BC1	IN	Bit clock input
15	SC1	IN	Serial data output (ch 1)
16	SI1	OUT	Serial data input (ch 1)

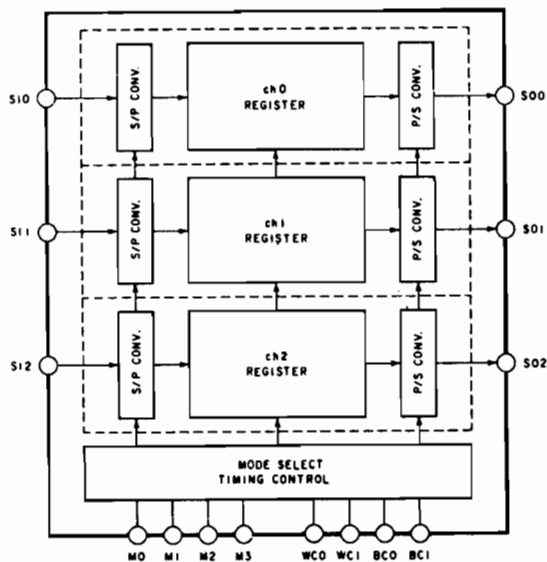

IC29 : HM65256BLP-10 or TC51832PL-10
32768-word x 8-bit High Speed Pseudo Static RAM

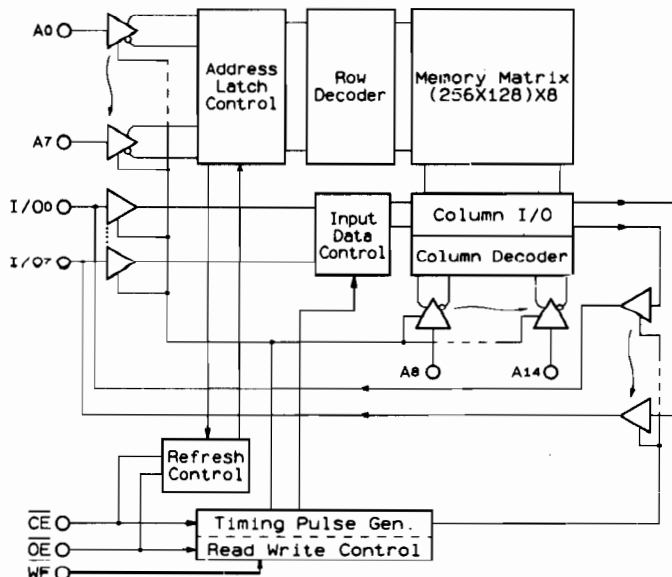
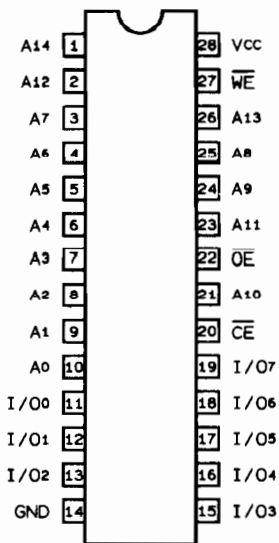

IC1 : HA17408P
8-bit Multiplying Digital - to - Analog Converter

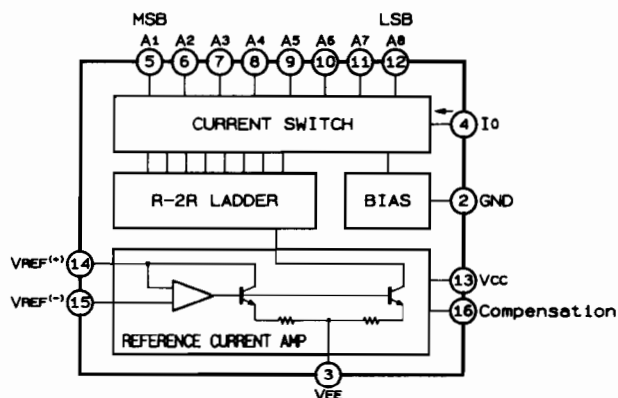
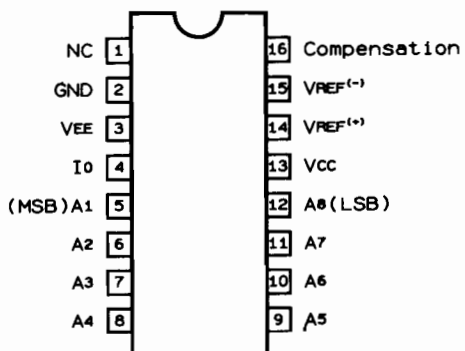

IC17 : AK9201A or AK9201
A/D Converter

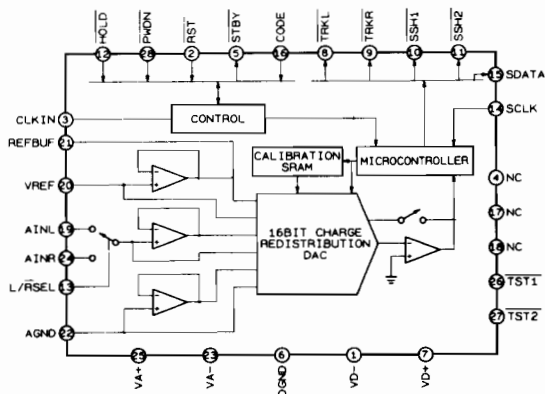

IC18, 19 : PCM56P
D/A Converter

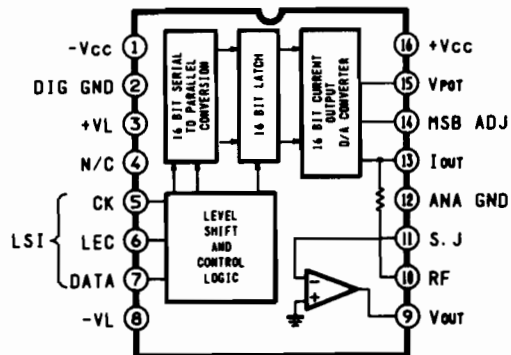

IC5 : LA2730
Dolby Encoder/Decoder

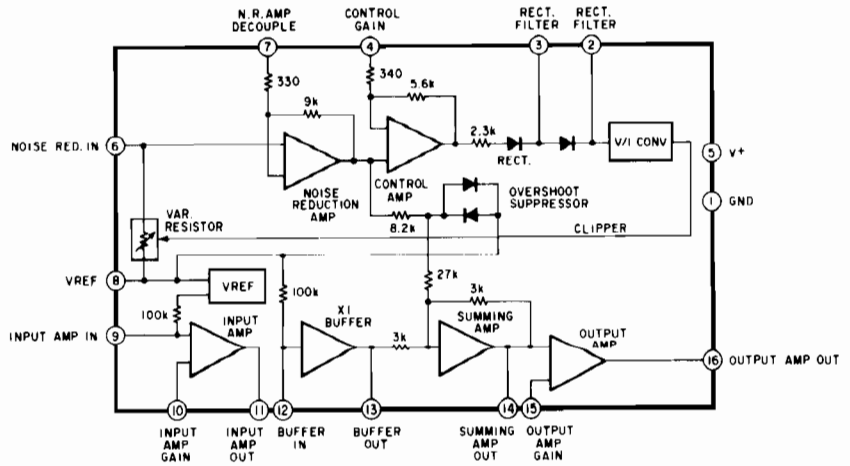
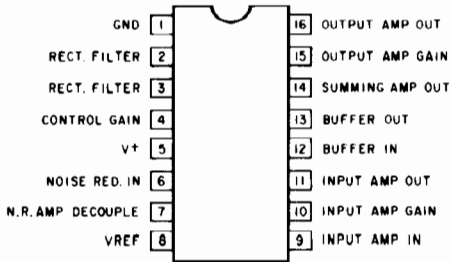

IC6 : LA2770
Dolby Pro Logic

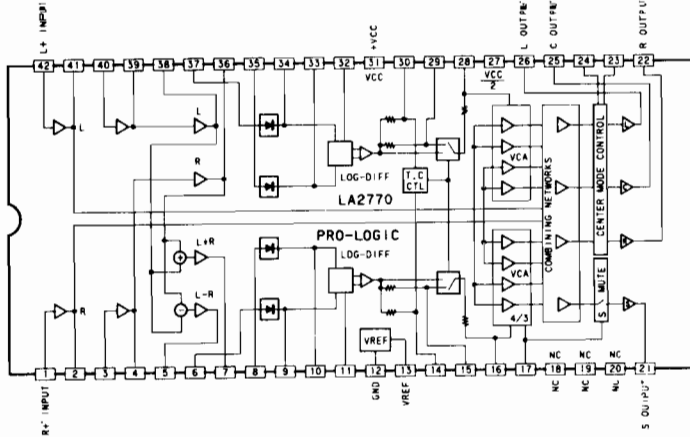

IC208, 210, 213, 216 : M51132L
2-Channel Volume/Balance Controller

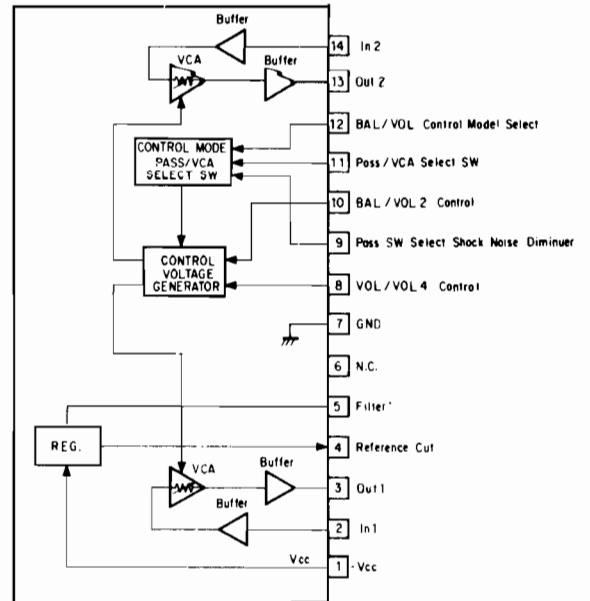

IC225 : LC7821N
Analog Function Switch

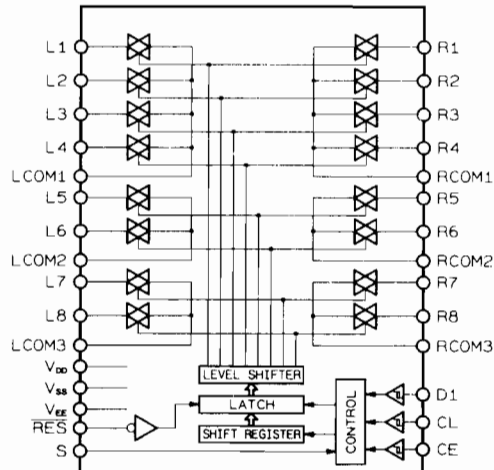
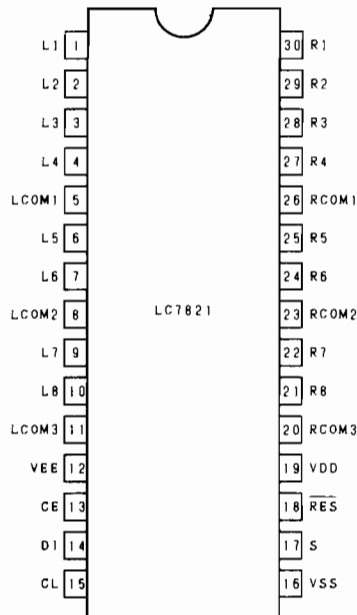

IC24 : μ PD74HC175G-T1 or MN74HC175S
Quad D-FFs

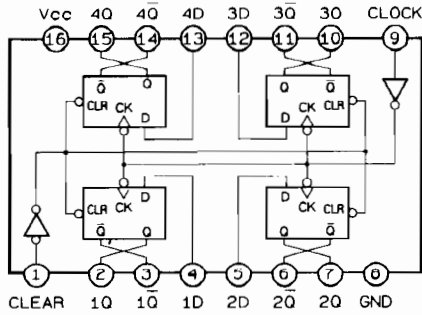

IC25 : μ PD74HC00G-T1
Quad 2-Input NAND Gate

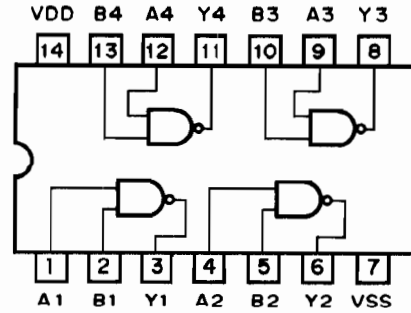

IC21, 22 : μ PD74HC74G-T1
Dual D-FFs with Preset and Clear

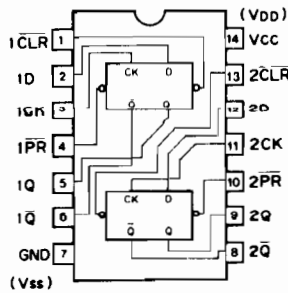

INPUTS				OUTPUTS	
PR	CLR	CLK	D	Q	\bar{Q}
L	H	X	X	H	L
H	L	X	X	L	H
L	L	X	X	H ¹	H ¹
H	H		H	H	L
H	H		L	L	H
H	H	L	X	Q ⁰	\bar{Q}^0

- Note) 1. X : Either "H" or "L"
 2. / : Rise in positive direction
 3. Q⁰ : Q level before the input conditions in the table are established.
 4. \bar{Q}^0 : Q level before the input conditions in the table are established.
 5. H¹ : When the preset and clear are "L", Q and \bar{Q} are "H" but when the preset and clear are made "H" simultaneously, the level of Q and \bar{Q} can not be predicted.

IC23 : μ PD74HC393G-T1 or MN74HC393S
Dual 4-Bit Binary Counters

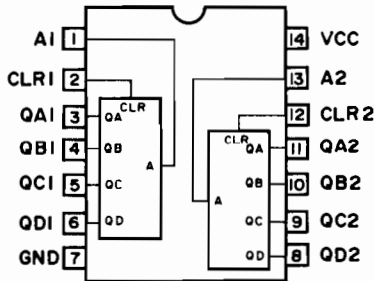

IC8 : TC4069UBP
IC20 : μ PD74HCU04G-T1 or MN74HCU04S
IC701 : μ PD74HCU04C
Hex Inverters

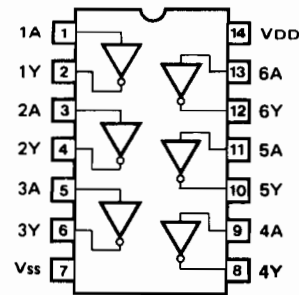

IC30, 31 : μ PD4053BC
IC205 : μ PD4053G-T1
IC215, 704 : TC4053BP
Triple-2 Channel Multiplexer/Demultiplexer

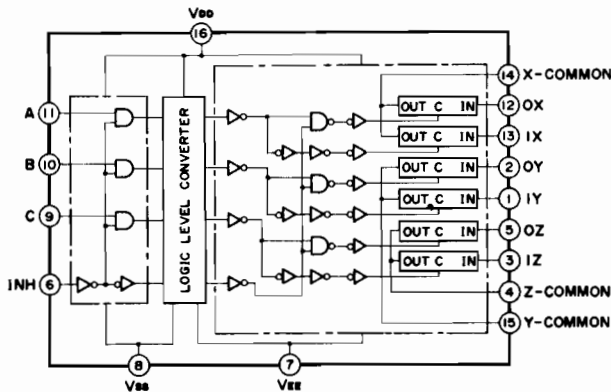

CONTROL INPUTS				"ON" CHANNEL
INHIBIT (Pin 6)	C (Pin 9)	B (Pin 10)	A (Pin 11)	0X (Pin 12), 0Y (Pin 2), 0Z (Pin 5) 1X (Pin 13), 1Y (Pin 1), 1Z (Pin 3)
L	L	L	L	0X, 0Y, 0Z
L	L	L	H	1X, 0Y, 0Z
L	L	H	L	0X, 1Y, 0Z
L	L	H	H	1X, 1Y, 0Z
L	H	L	L	0X, 0Y, 1Z
L	H	L	H	1X, 0Y, 1Z
L	H	H	L	0X, 1Y, 1Z
L	H	H	H	1X, 1Y, 1Z
H	*	*	*	NOTE

* Don't Care

IC4 : DT5A143E
Transistor Array

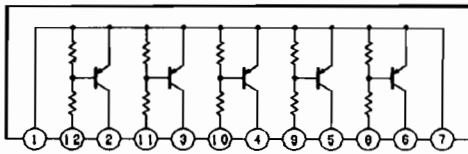

IC14, 16 : M5238L
Dual Ope-amp

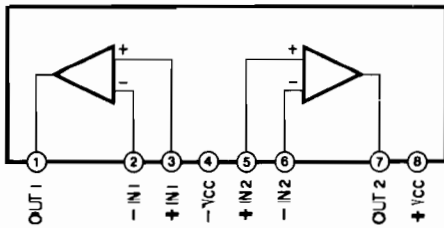

IC9~13, 15, 202, 204, 206, 207, 211,
212, 217, 218, 224 : μ PC4570HA
IC203 : μ PC4072HA
IC209 : NJM4556S
Dual Ope-amp

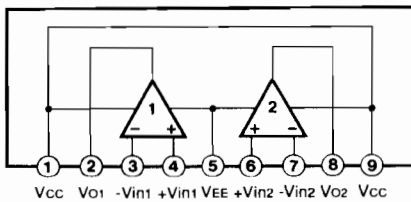

IC702 : LA7213
Video Sync. Sep.

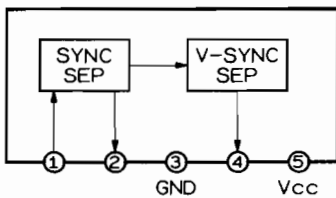

IC201 : μ PC4570G2-T1
Dual Ope-amp

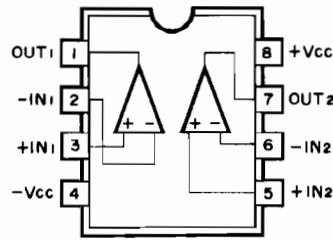

IC36, IC214 : μ PC4574C
4-channel Ope-amp

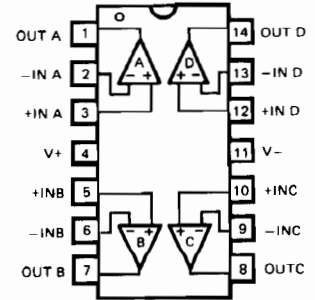

IC219~223 : μ PC1188H
Power Amp

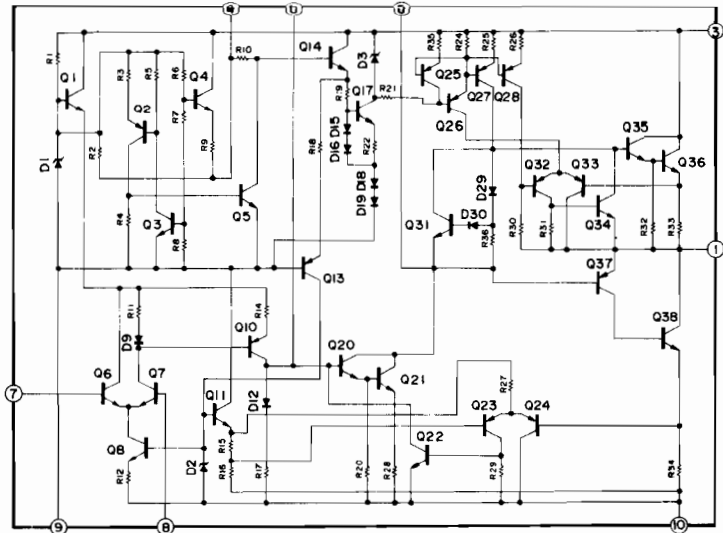

UI : GP1U501X
Remote Control Receptor

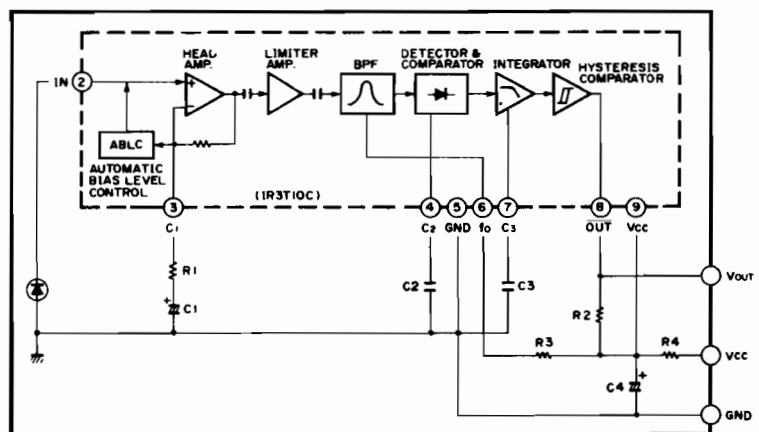

■ BLOCK DIAGRAM

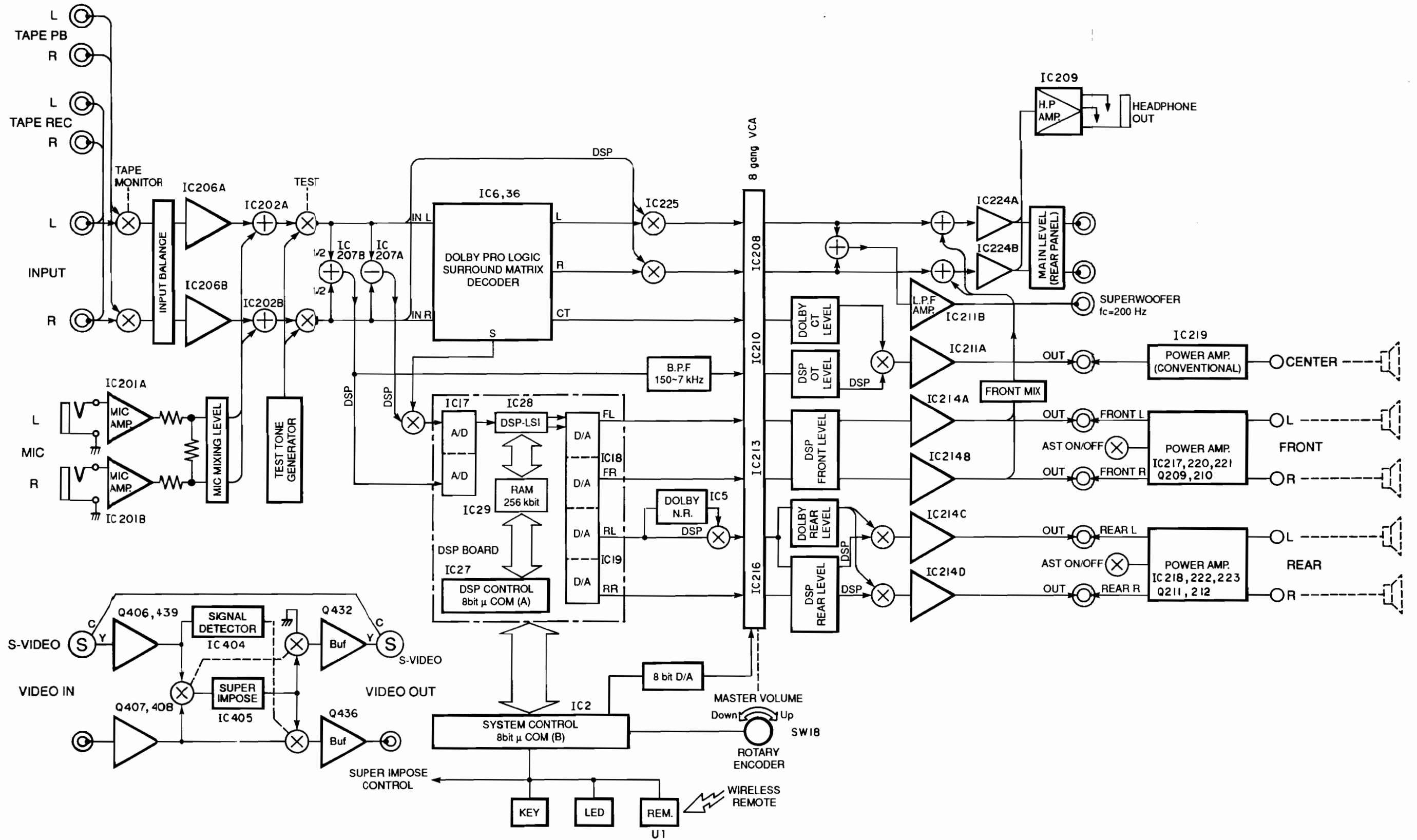

■ INTERCONNECT WIRING DIAGRAM

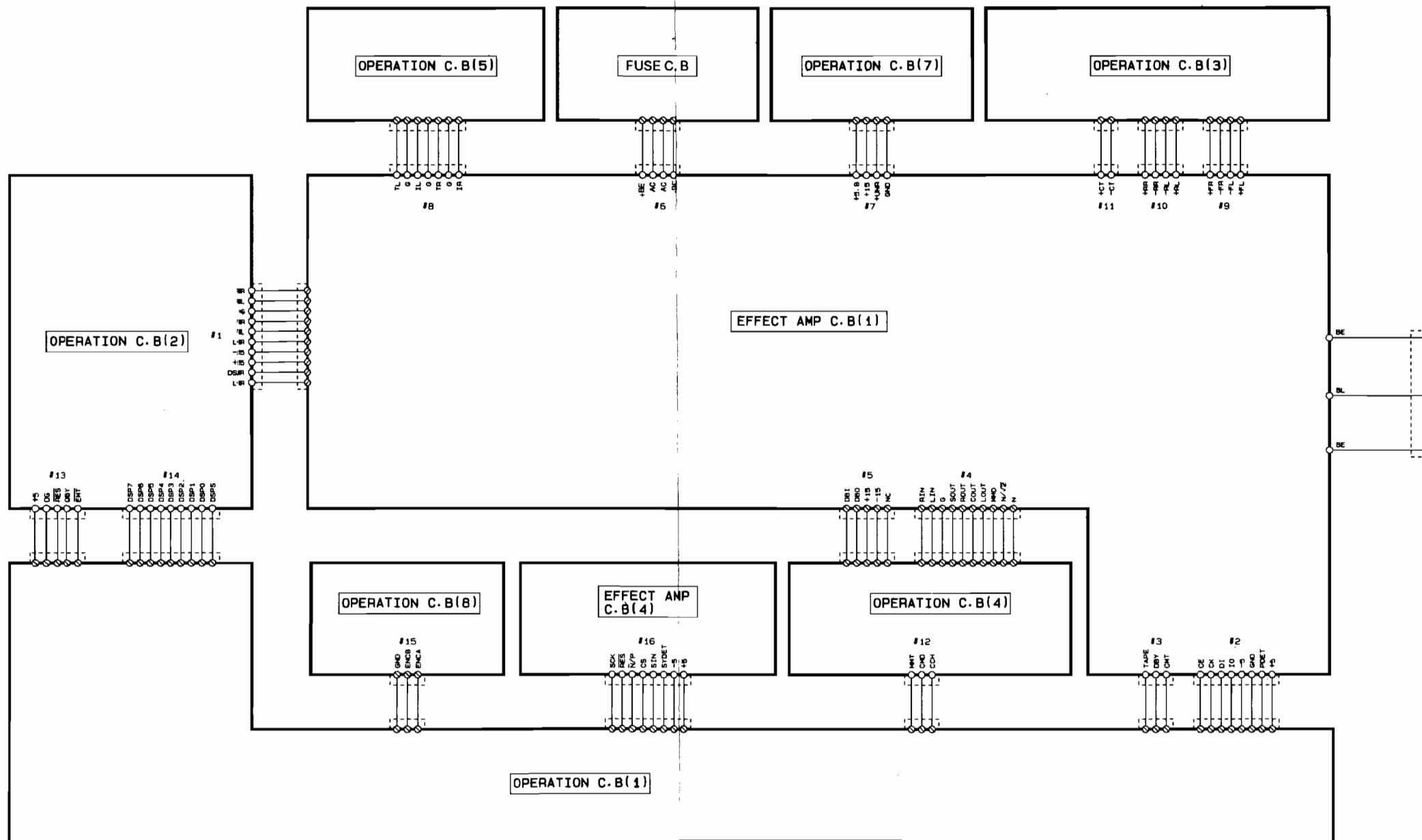

<J.U.C>

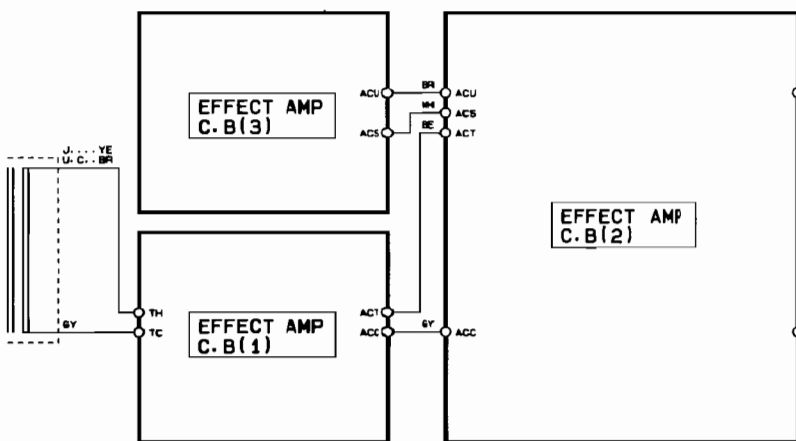

<R>

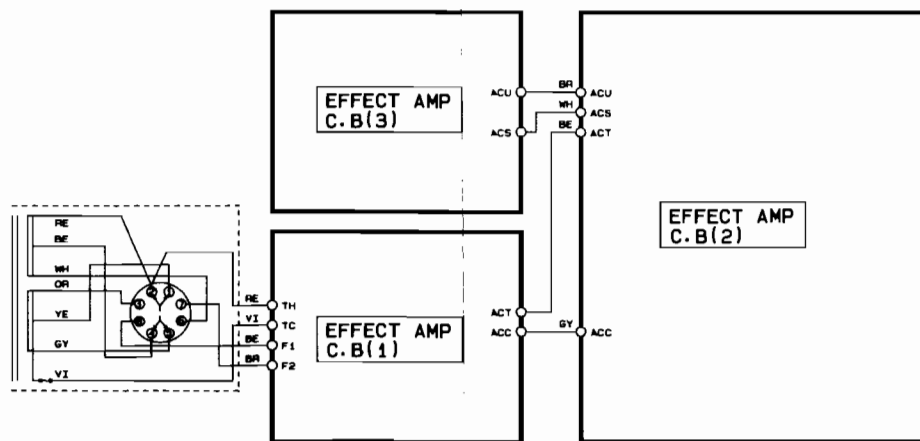

<A.B.G>

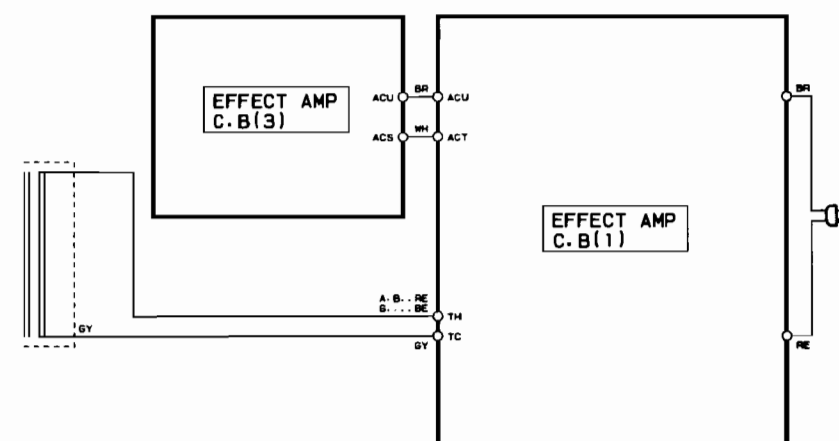

■ SCHEMATIC DIAGRAM (1/4) OPERATION C. B B

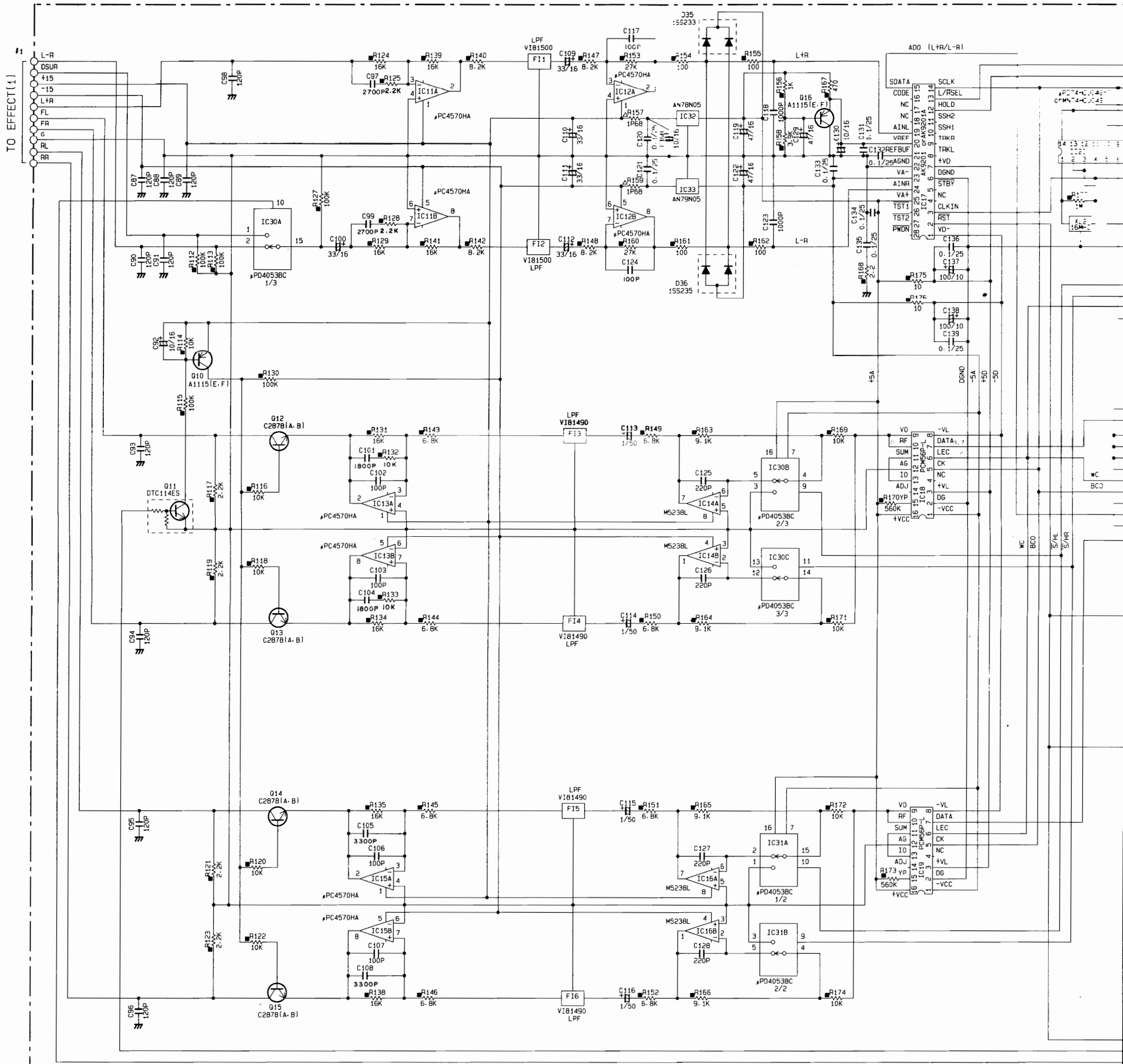

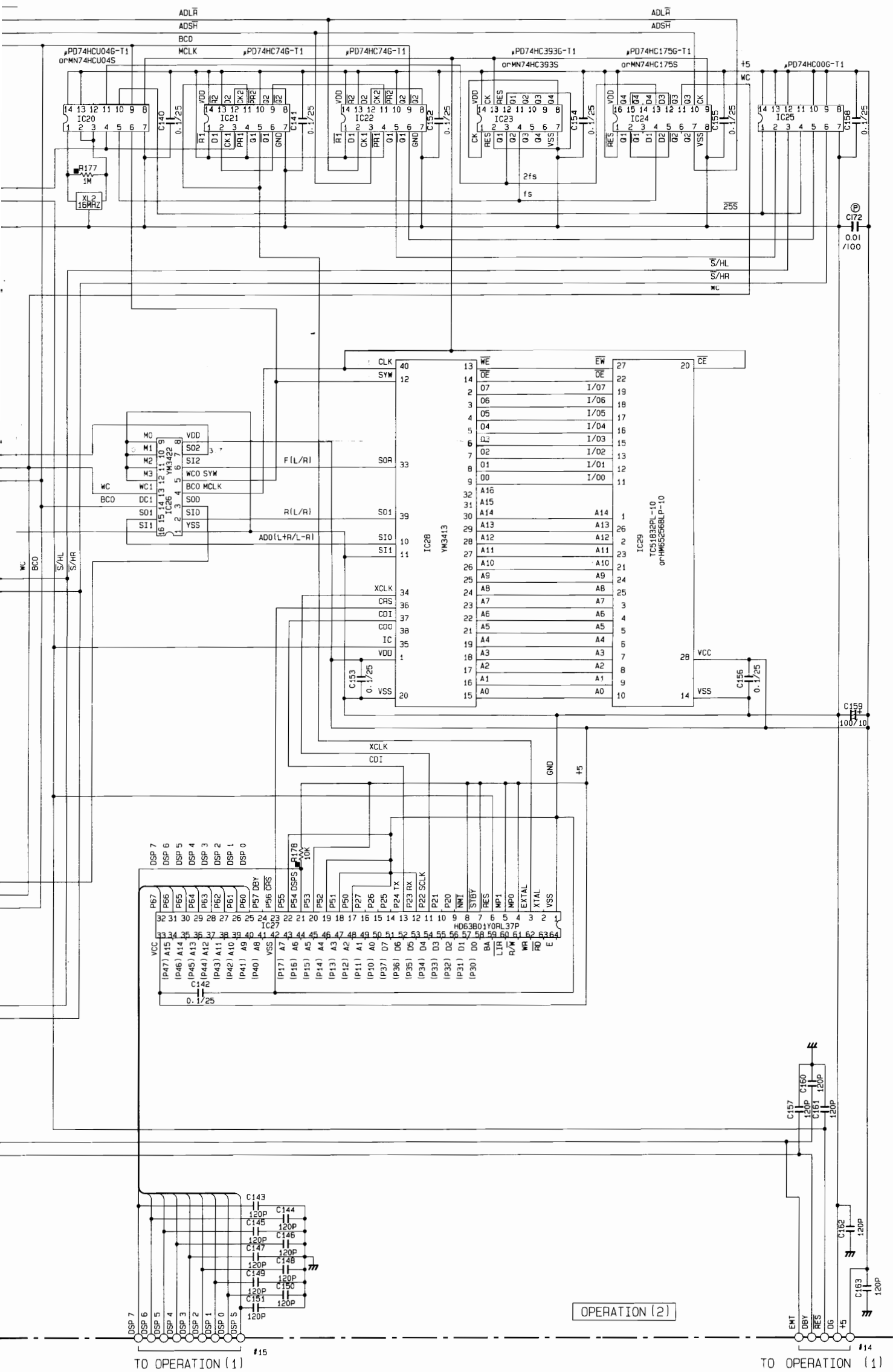

NOTICE
 (J)..... Japanese model
 (U)..... U.S.A model
 (C)..... Canadian model
 (A)..... Australian model
 (G)..... European model
 (B)..... British model
 (R)..... General model
 (P)..... RP model

REMARKS	PARTS NAME	
NO MARK	ELECTROLYTIC CAPACITOR	⊕
⊗	TANTALUM CAPACITOR	⊕
NO MARK	CERAMIC CAPACITOR	
⊙	POLYESTER FILM CAPACITOR	
○	POLYSTYRENE FILM CAPACITOR	
⊖	MICA CAPACITOR	
⊕	POLYPROPYLENE FILM CAPACITOR	
●	SEMICONDUCTIVE CERAMIC CAPACITOR	

REMARKS	PARTS NAME
NO MARK	CARBON FILM RESISTOR (1/6W)
⊠	CARBON FILM RESISTOR (1/4W)
△	METAL OXIDE FILM RESISTOR
▲	METEL FILM RESISTOR
⊞	METEL PLATE RESISTOR
⊞	FIRE PROOF CARBON FILM RESISTOR
□	SEMENT MOLDED RESISTOR
⊞	SEMI VARIABLE RESISTOR
■	CHIP RESISTOR

MAIN EFFECT	MAIN AMP	EFFECT AMP

A1115(E, F) or A9335(I, R) or A1309A(Q, R, S)
 C2878(A, B) or C3327 or D1915(S, T)

OPERATION		
	LAST NO.	UN LISTED NO.
C	171	
R	184	
G	16	
D	37	
IC	35	

* All voltage are measured with a 10MΩ/DC electric volt meter.
 * Components having special characteristics are marked △ and must be replaced with parts having specifications equal to those originally installed.
 * Schematic diagram is subject to change without notice.

■ SCHEMATIC DIAGRAM (1/4) OPERATION C. B C / D

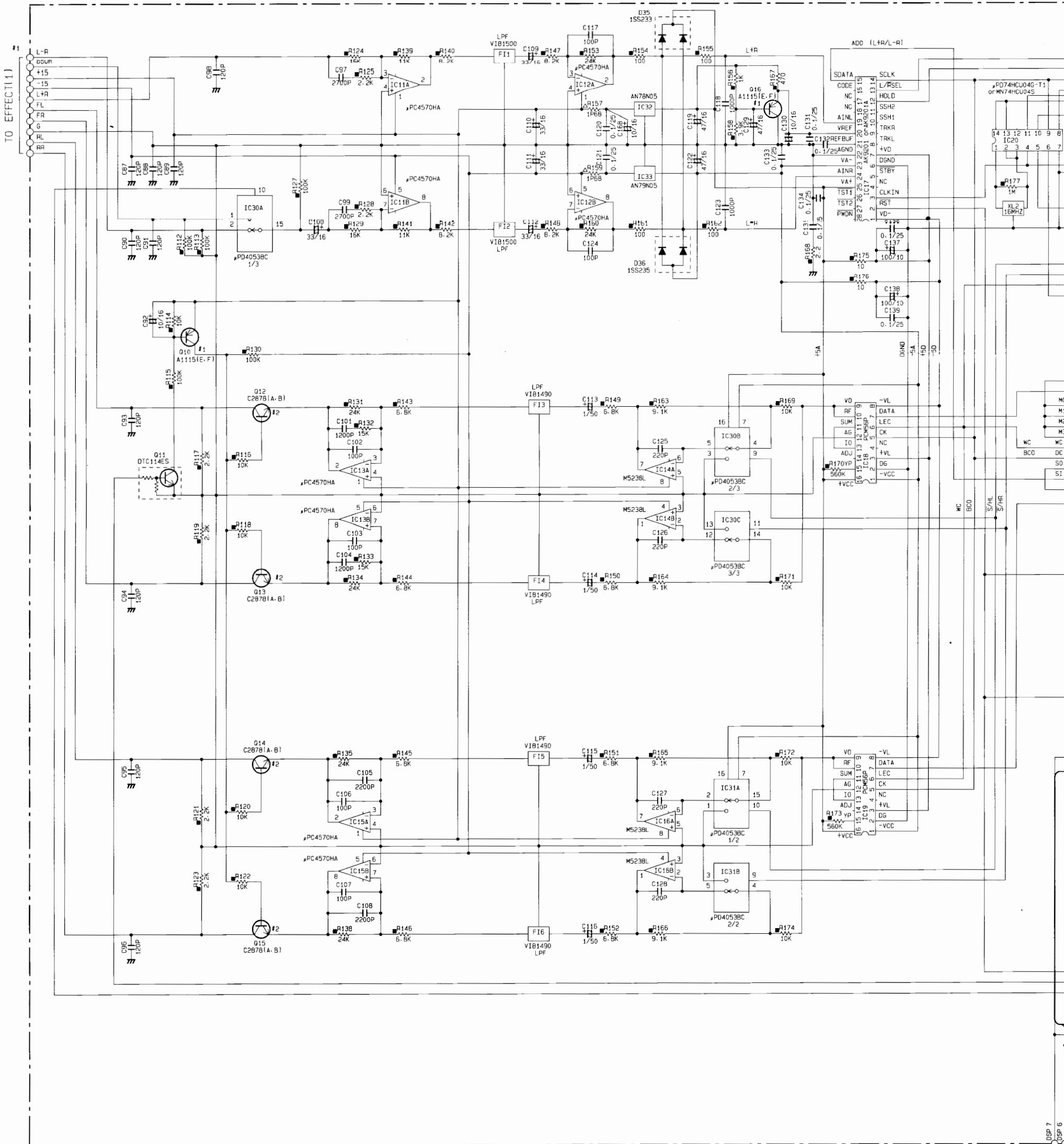

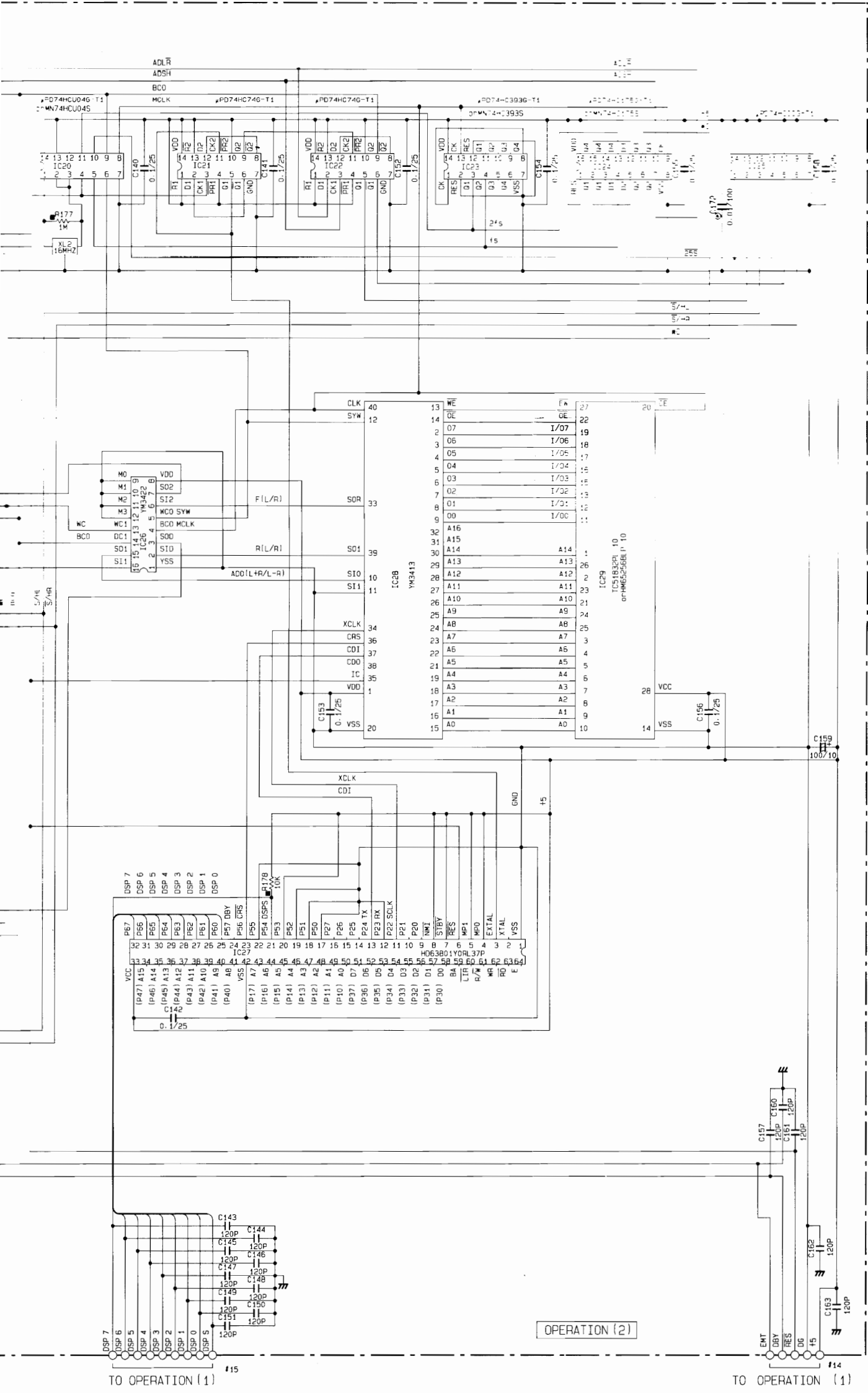

NOTICE
 (J)..... Japanese Code
 (U)..... U.S.A. Code
 (C)..... Canadian Code
 (A)..... Australian Code
 (G)..... European Code
 (B)..... British Code
 (R)..... General Code
 (P)..... RP Code

CAPACITOR

REMARKS	PARTS NAME
NO MARK	ELECTROLYTIC CAPACITOR
⊖	TANTALUM CAPACITOR
NO MARK	CERAMIC CAPACITOR
⊖	POLYESTER FILM CAPACITOR
⊖	POLYSTYRENE FILM CAPACITOR
⊖	MICA CAPACITOR
⊖	POLYPROPYLENE FILM CAPACITOR
⊖	SEMICONDUCTIVE CERAMIC CAPACITOR

RESISTOR

REMARKS	PARTS NAME
NO MARK	CARBON FILM RESISTOR (1/6W)
⊖	CARBON FILM RESISTOR (1/4W)
⊖	METAL OXIDE FILM RESISTOR
⊖	METAL FILM RESISTOR
⊖	METAL PLATE RESISTOR
⊖	FIRE PROOF CARBON FILM RESISTOR
⊖	CEMENT MOUNTED RESISTOR
⊖	SEMI-VARIABLE RESISTOR
⊖	CHIP RESISTOR

Interchangeable Parts at Manufacture-Stage

Mark	Reference Parts Number	Parts Name
#1	Q10-16	2SA1115(E.F) 2SA933S(Q.R) 2SA1309A(Q.R.S)
#2	Q12-15	2SC287B(A.B) 2SC3327 2SD1915

MAIN	MAIN AMP
EFFECT	EFFECT AMP

OPERATION

	LAST NO.	UN LISTED NO.
C	177	
R	201	
Q	16	
D	37	
IC	36	

* All voltage are measured with a 10MΩ/DC electric volt meter
 * Components having special characteristics are marked Δ and must be replaced with parts having specifications equal to those originally installed.
 * Schematic diagram is subject to change without notice.

■ SCHEMATIC DIAGRAM (2/4) OPERATION C. B **B**

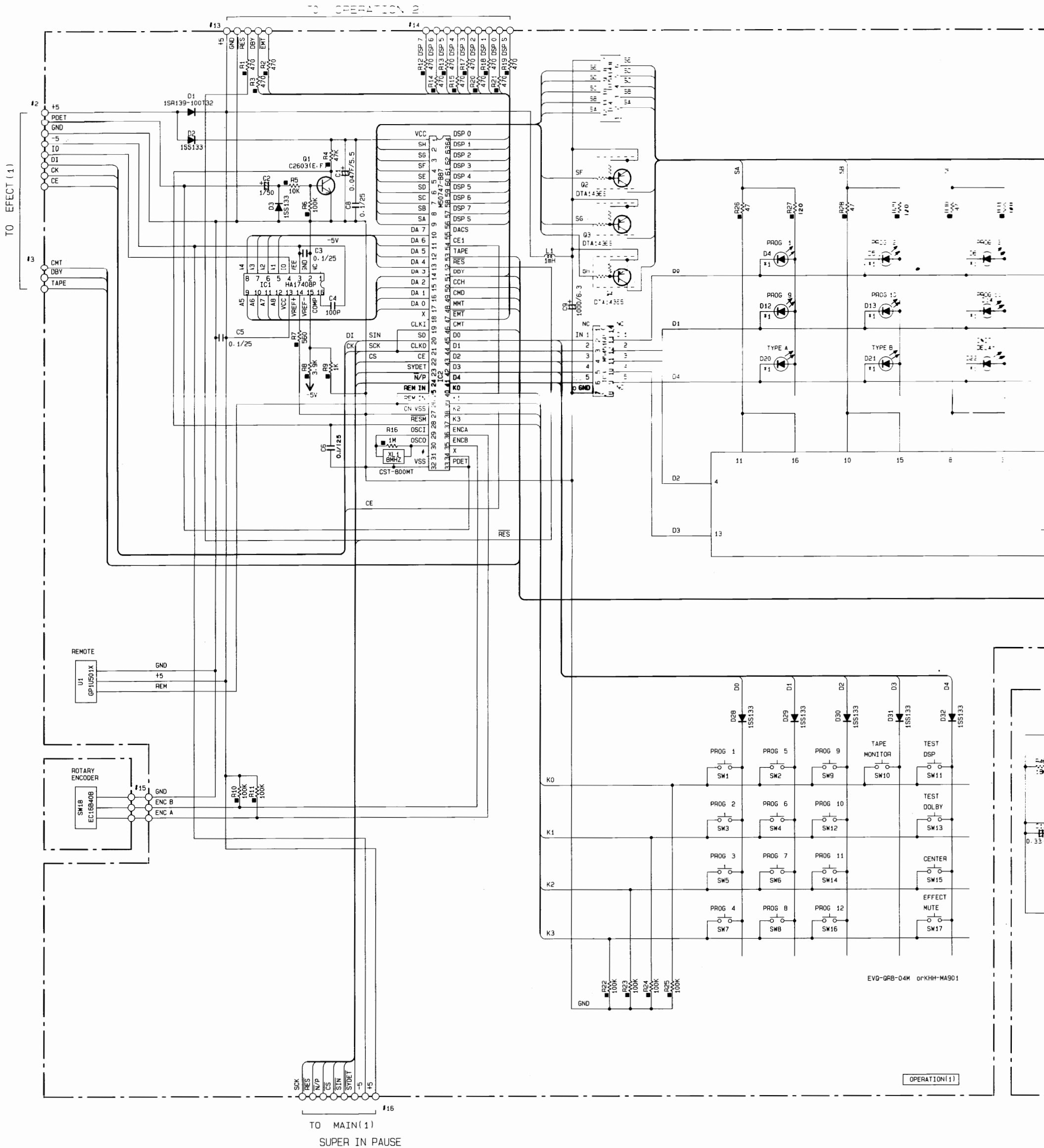

NOTICE
 (J)..... Japanese model
 (U)..... U.S.A model
 (C)..... Canadian model
 (A)..... Australian model
 (G)..... European model
 (B)..... British model
 (R)..... General model
 (P)..... AP model

REMARKS	PARTS NAME
NO MARK	CARBON FILM RESISTOR (1/6W)
□	CARBON FILM RESISTOR (1/4W)
△	METAL OXIDE FILM RESISTOR
▲	METAL FILM RESISTOR
⊠	METAL PLATE RESISTOR
⊞	FIRE PROOF CARBON FILM RESISTOR
□	SEMENT MOLDED RESISTOR
⊞	SEMI VARIABLE RESISTOR
■	CHIP RESISTOR

REMARKS	PARTS NAME
NO MARK	ELECTROLYTIC CAPACITOR
⊗	TANTALUM CAPACITOR
NO MARK	CERAMIC CAPACITOR
⊙	POLYESTEL FILM CAPACITOR
○	POLYSTYRENE FILM CAPACITOR
⊖	MICA CAPACITOR
⊕	POLYPROPYLENE FILM CAPACITOR
●	SEMICONDUCTIVE CERAMIC CAPACITOR

MAIN	MAIN AMP
EFFECT	EFFECT AMP

A1115(E.F)	orA9335(Q.R)	orA1309A(Q.R.S)
C2603(E.F)	orC17405(S.R)	orC3311A(Q.R.S)

OPERATION	
LAST NO.	UN LISTED NO.
C 171	
R 184	
Q 16	
D 37	
IC 35	

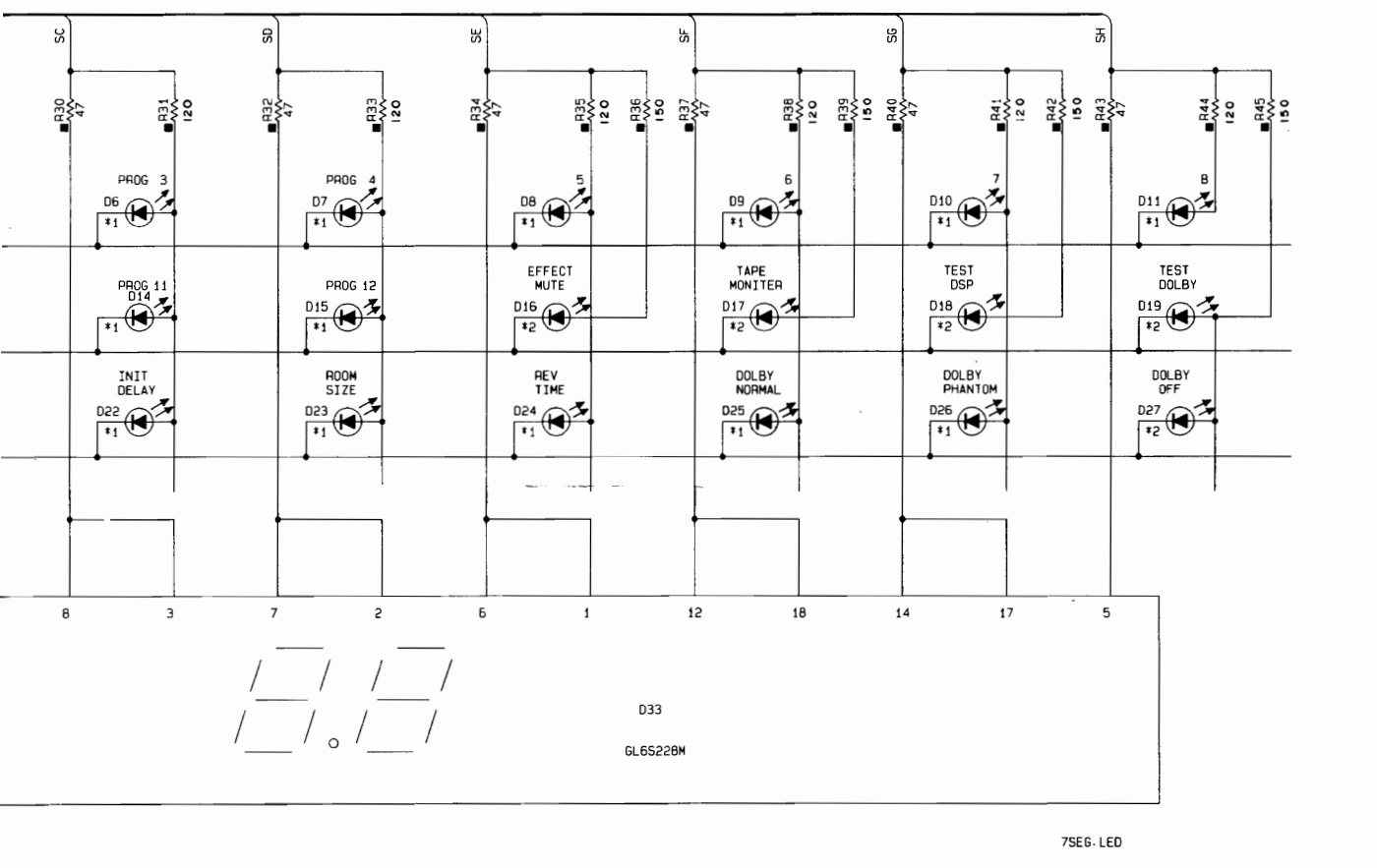

LED #1 SLR-340C3H3
 #2 SLR-34VC3H3

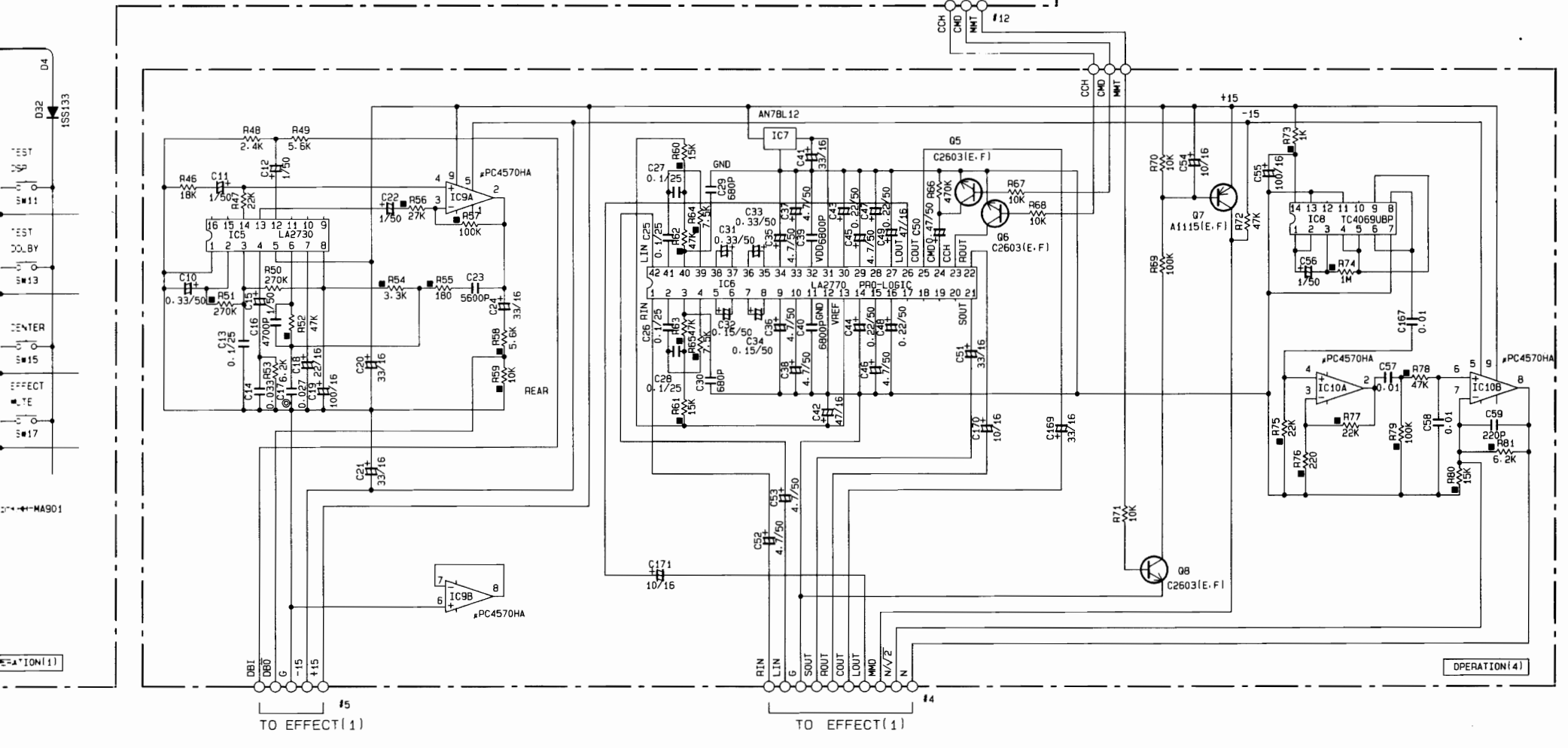

* All voltage are measured with a 10MΩ/DC electric volt meter.
 * Components having special characteristics are marked Δ and must be replaced with parts having specifications equal to those originally installed.
 * Schematic diagram is subject to change without notice.

SCHEMATIC DIAGRAM (2/4) OPERATION C. B C / D

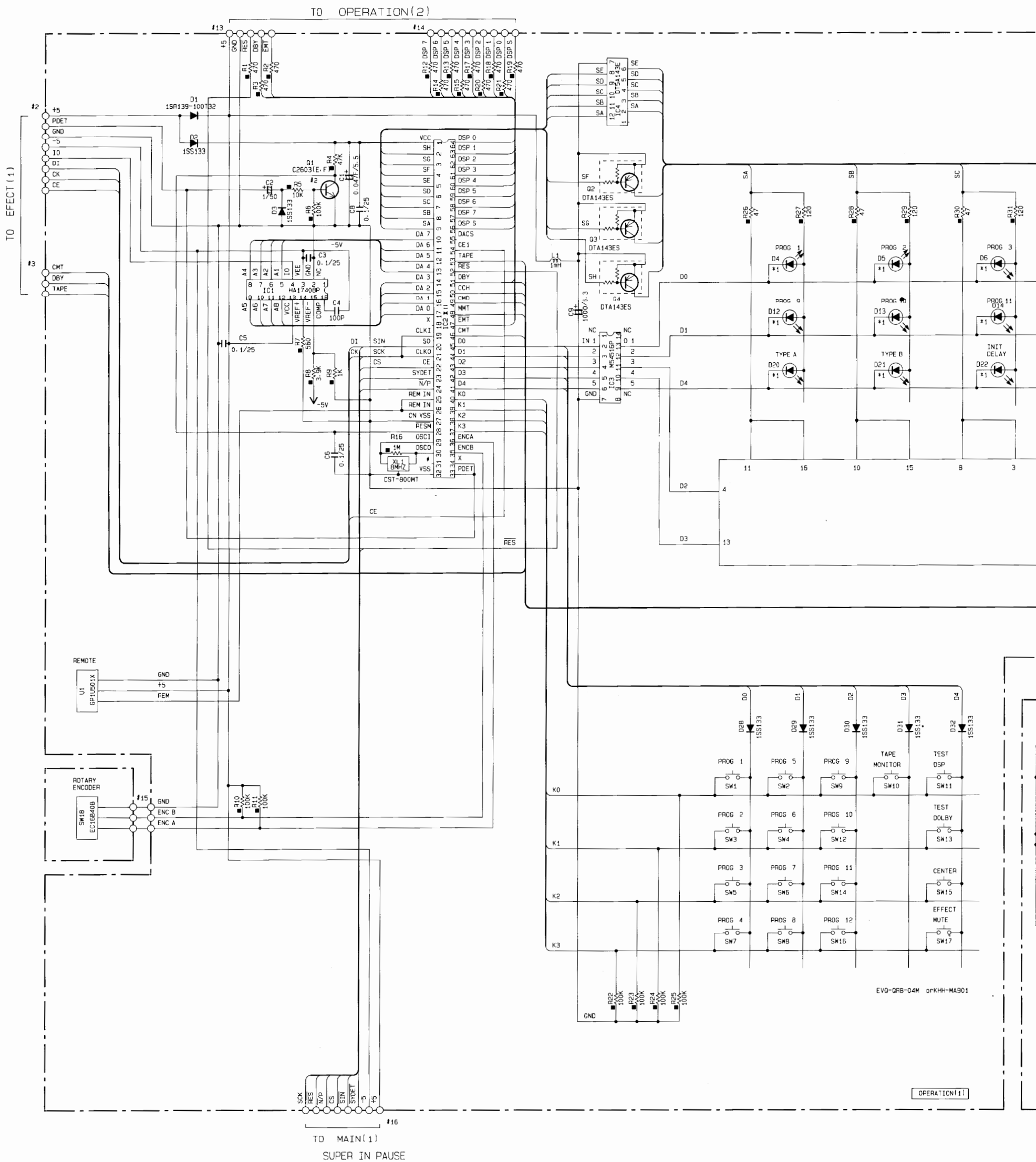

NOTICE
 (J)..... Japanese model
 (U)..... U.S.A model
 (C)..... Canadian model
 (A)..... Australian model
 (G)..... European model
 (B)..... British model
 (R)..... General model
 (P)..... RP model

REMARKS	PARTS NAME
NO MARK	CARBON FILM RESISTOR (1/6W)
□	CARBON FILM RESISTOR (1/4W)
△	METAL OXIDE FILM RESISTOR
▲	METAL FILM RESISTOR
⊠	METAL PLATE RESISTOR
⊞	FIRE PROOF CARBON FILM RESISTOR
□	CEMENT MOLDED RESISTOR
⊙	SEMI VARIABLE RESISTOR
■	CHIP RESISTOR

REMARKS	PARTS NAME
NO MARK	ELECTROLYTIC CAPACITOR
⊗	TANTALUM CAPACITOR
NO MARK	CERAMIC CAPACITOR
⊙	POLYESTER FILM CAPACITOR
○	POLYSTYRENE FILM CAPACITOR
⊖	MICA CAPACITOR
⊕	POLYPROPYLENE FILM CAPACITOR
●	SEMICONDUCTIVE CERAMIC CAPACITOR

MAIN	MAIN AMP
EFFECT	EFFECT AMP

Mark	Reference Parts Number	Parts Name
#1	07	2SA1115(E-F) 2SA9335(G-R) 2SA1309A(I-G, R-S)
#2	01-5-6-8	2SC1740S(S-R) 2SC2603(E-F) 2SC3311A(I-G, R-S)

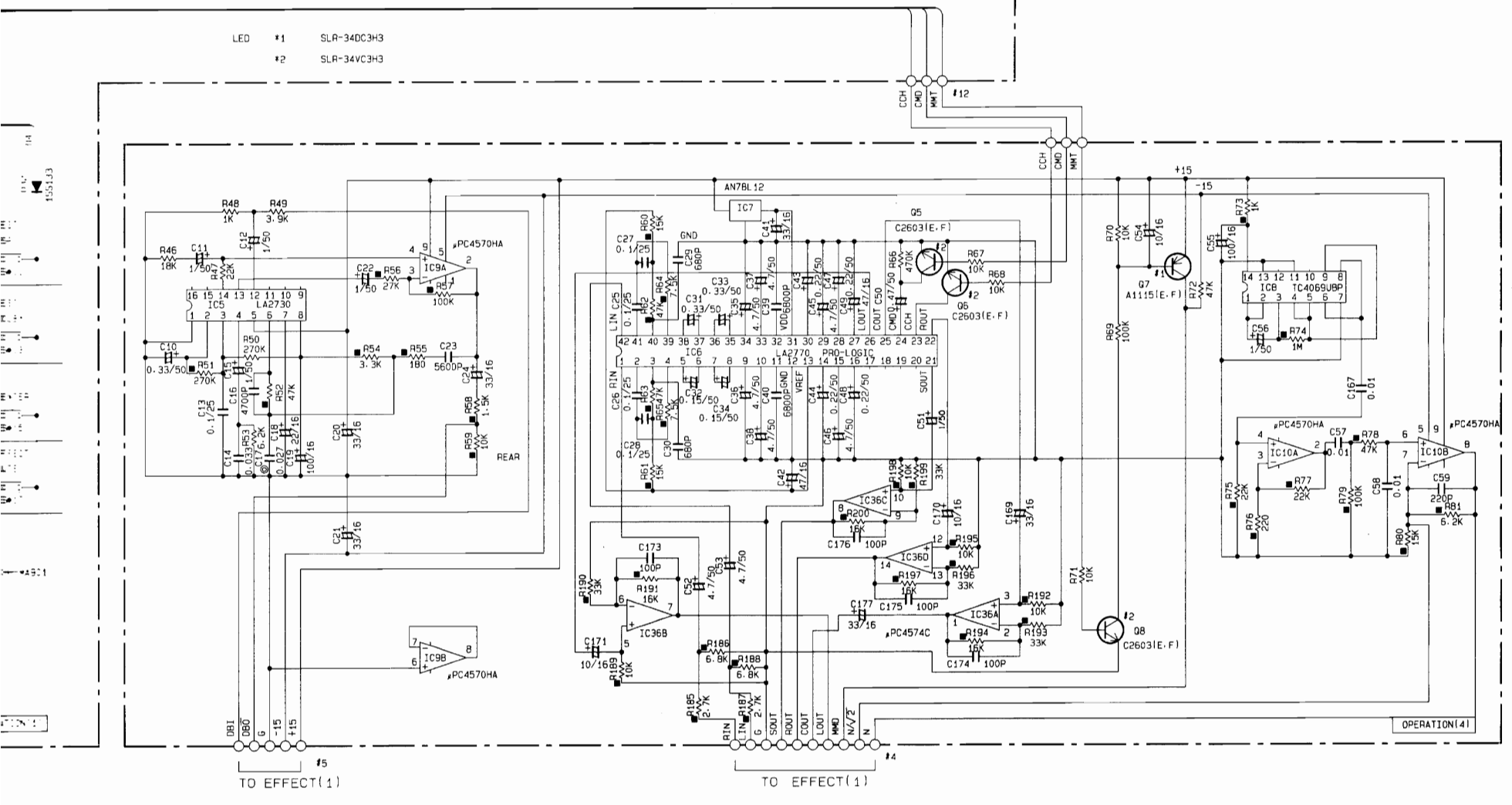
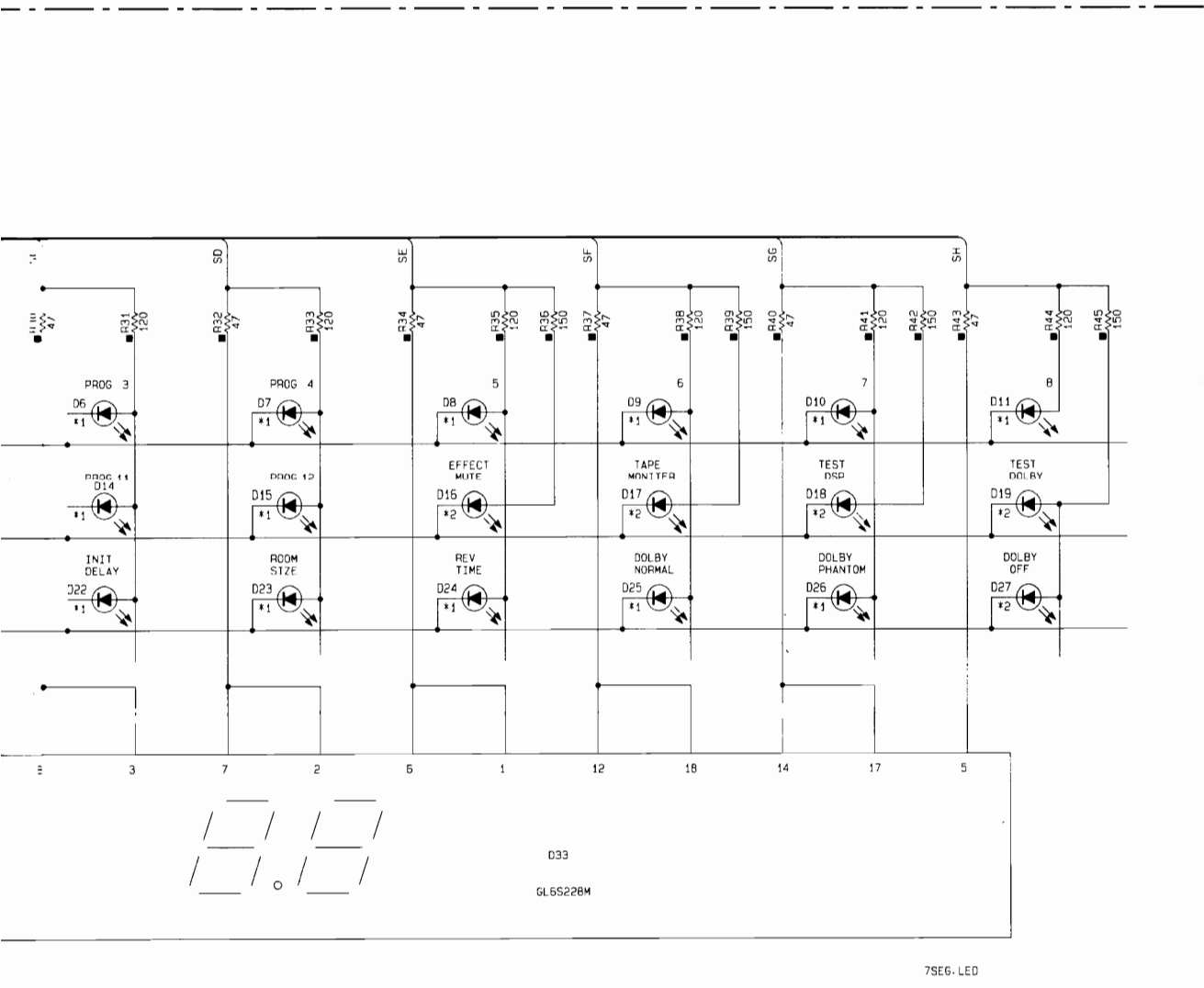

X	J	U.C	R,A,B,G
II IC2	M50747-B87	M50747-C36	M50747-B87

* All voltage are measured with a 10MΩ/DC electric volt meter.
 * Components having special characteristics are marked Δ and must be replaced with parts having specifications equal to those originally installed.
 * Schematic diagram is subject to change without notice.

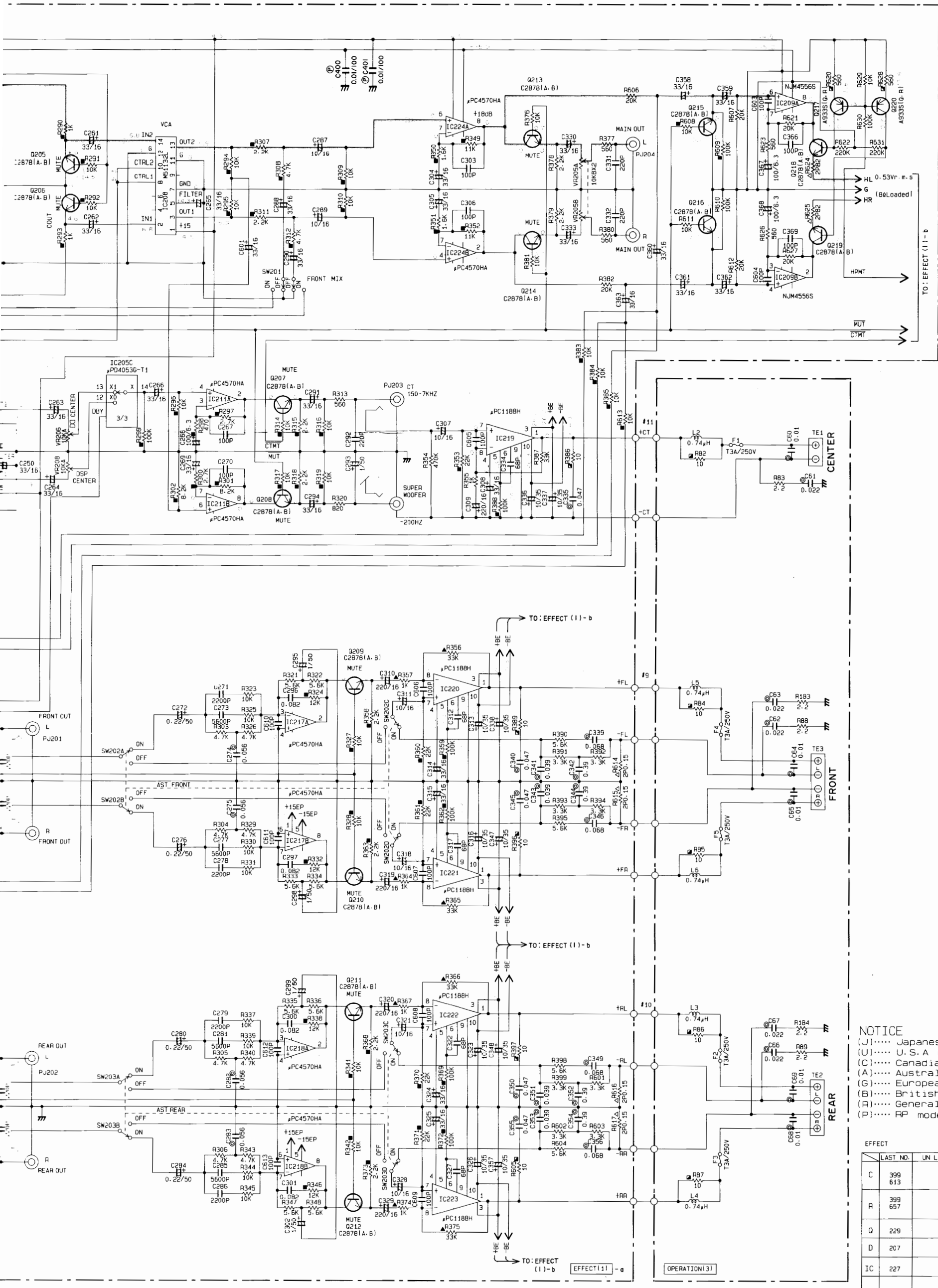

NOTICE
 (J)..... Japanese model
 (U)..... U.S.A model
 (C)..... Canadian model
 (A)..... Australian model
 (G)..... European model
 (B)..... British model
 (R)..... General model
 (P)..... RP model

EFFECT	LAST NO.	UN LISTED NO.
C	399 613	
R	399 657	
Q	229	
D	207	
IC	227	

* All voltage are measured with a 10MΩ/DC electric volt meter.
 * Components having special characteristics are marked Δ and must be replaced with parts having specifications equal to those originally installed.
 * Schematic diagram is subject to change without notice.

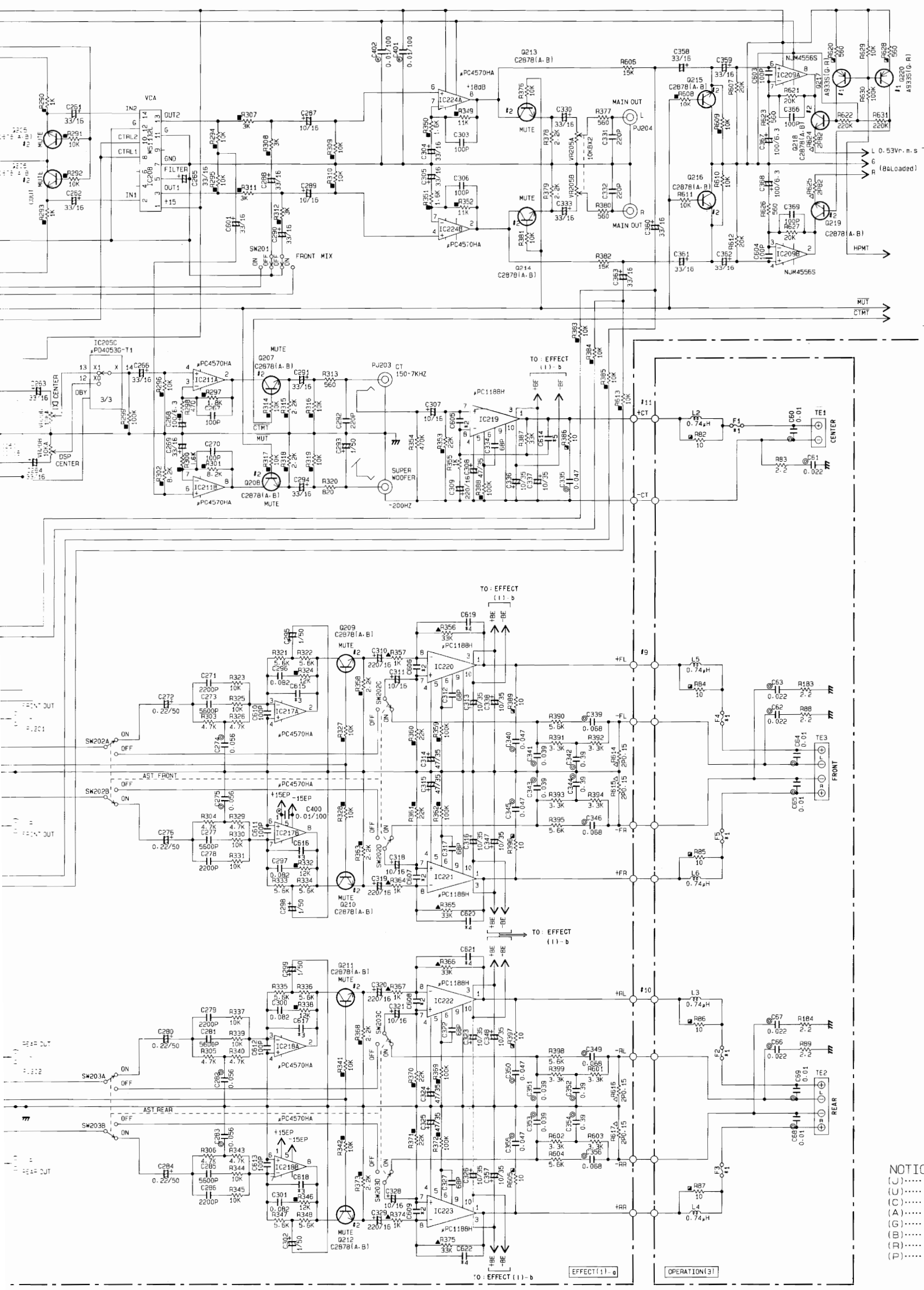

TO EFFECT (1)-b

NOTICE
 (J)..... Japanese model
 (U)..... U.S.A model
 (C)..... Canadian model
 (A)..... Australian model
 (B)..... European model
 (G)..... British model
 (R)..... General model
 (P)..... RP model

* All voltage are measured with a 10MΩ/DC electric volt met
 * Components having special characteristics are marked Δ
 and must be replaced with parts having specifications equ
 to those originally installed.
 * Schematic diagram is subject to change without notice.

■ SCHEMATIC DIAGRAM (4/4)EFFECT AMP C. B [C

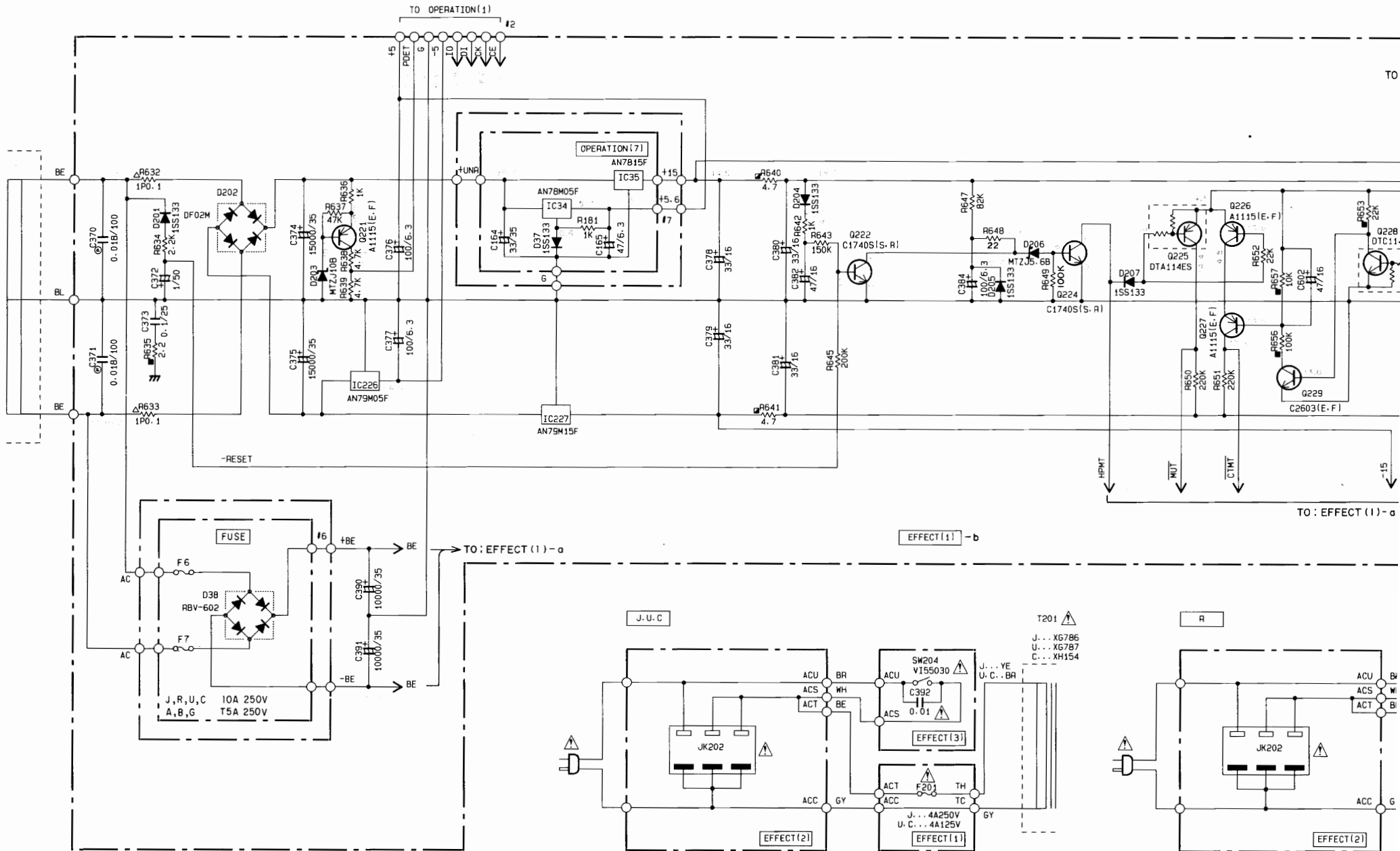
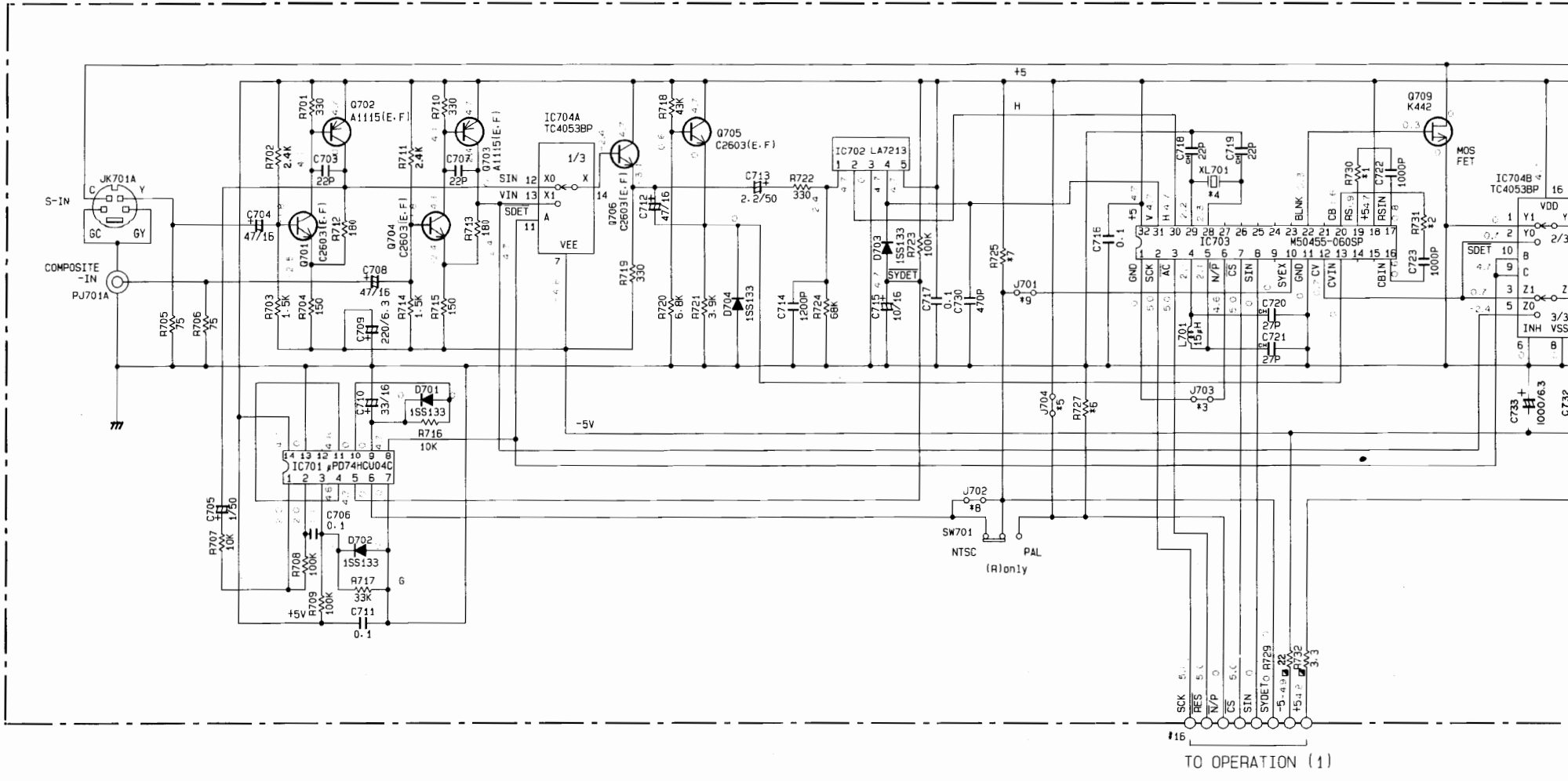

TO OPERATION (1)

TO OPERATION(1)

TO: EFFECT (1) - a

EFFECT(1) - b

TO: EFFECT (1) - a

T201
J... XG786
U... XG787
C... XH154

J.U.C

R

EFFECT(2)

EFFECT(1)

EFFECT(3)

EFFECT(2)

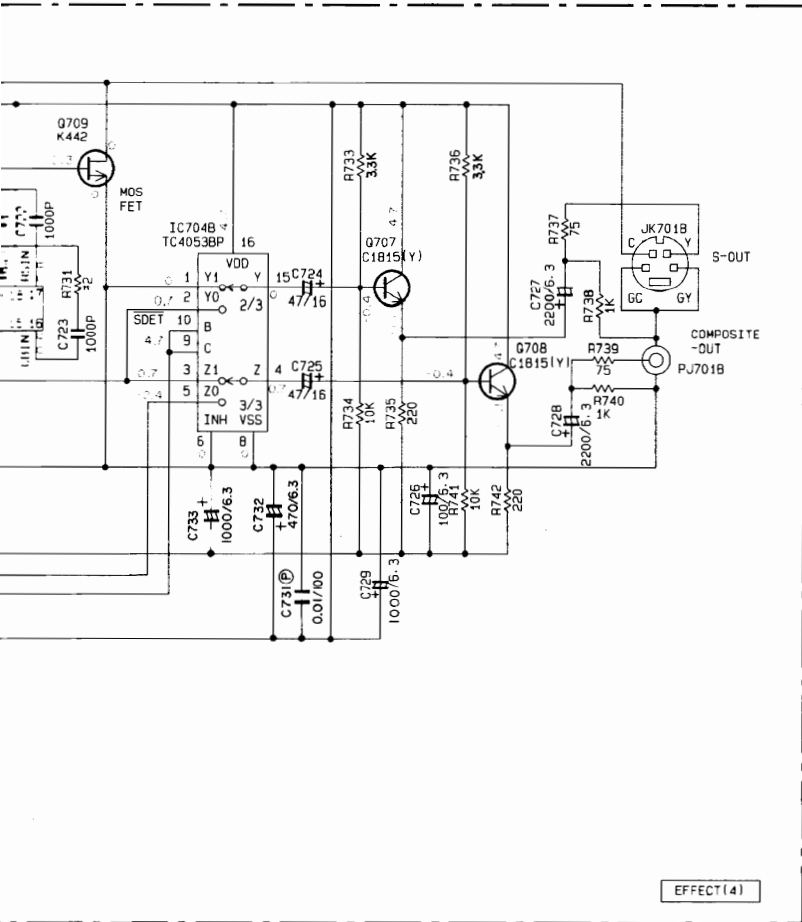

MAIN	MAIN AMP
EFFECT	EFFECT AMP

A1115(E.F)	or A9335(G.R)	or A1309A(G.R.S)
C2603(E.F)	or C1740(S.R)	or C3311A(G.R.S)
C2878(A.B)	or C3327	or D1915

	J	U.C	R	A.B.G
#1	R730	10K		2.7K
#2	R731	10K		4.7K
#3	J703	OPEN		SHORT
#4	XL701	14.3MHZ		17.7MHZ
#5	J704	OPEN		SHORT
#6	R727	SHORT	100K	OPEN
#7	R725	OPEN	10K	OPEN
#8	J702	SHORT	OPEN	SHORT
#9	J701	SHORT	OPEN	SHORT

NOTICE
 (J)..... Japanese model
 (U)..... U.S.A model
 (C)..... Canadian model
 (A)..... Australian model
 (G)..... European model
 (B)..... British model
 (R)..... General model
 (P)..... RP model

RESISTOR

REMARKS	PARTS NAME
NO MARK	CARBON FILM RESISTOR (1/6W)
☑	CARBON FILM RESISTOR (1/4W)
△	METAL OXIDE FILM RESISTOR
▲	METEL FILM RESISTOR
⊠	METEL PLATE RESISTOR
⊞	FIRE PROOF CARBON FILM RESISTOR
□	SEMENT MOLDED RESISTOR
⊙	SEMI VARIABLE RESISTOR
■	CHIP RESISTOR

CAPACITOR

REMARKS	PARTS NAME	
NO MARK	ELECTROLYTIC CAPACITOR	⊥
⊗	TANTALUM CAPACITOR	⊥
NO MARK	CERAMIC CAPACITOR	
⊙	POLYESTEL FILM CAPACITOR	
○	POLYSTYRENE FILM CAPACITOR	
⊖	MICA CAPACITOR	
⊕	POLYPROPYLENE FILM CAPACITOR	
●	SEMICONDUCTIVE CERAMIC CAPACITOR	

EFFECT

	LAST NO.	UN LISTED NO.
C	730	
R	742	
Q	709	
D	704	
IC	704	

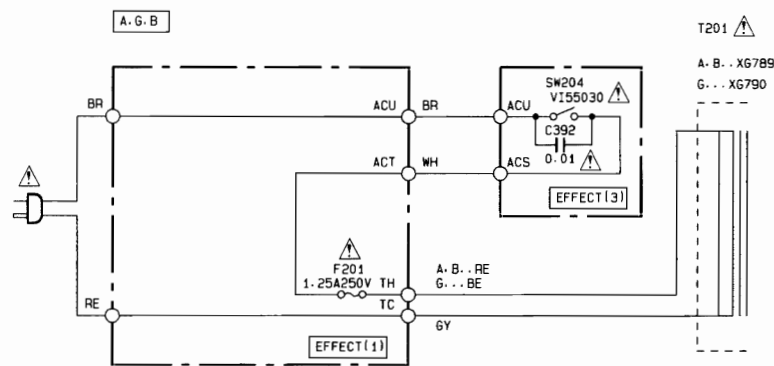
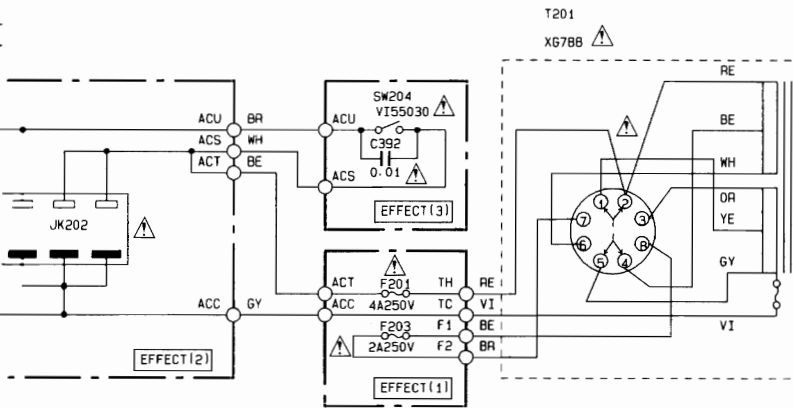
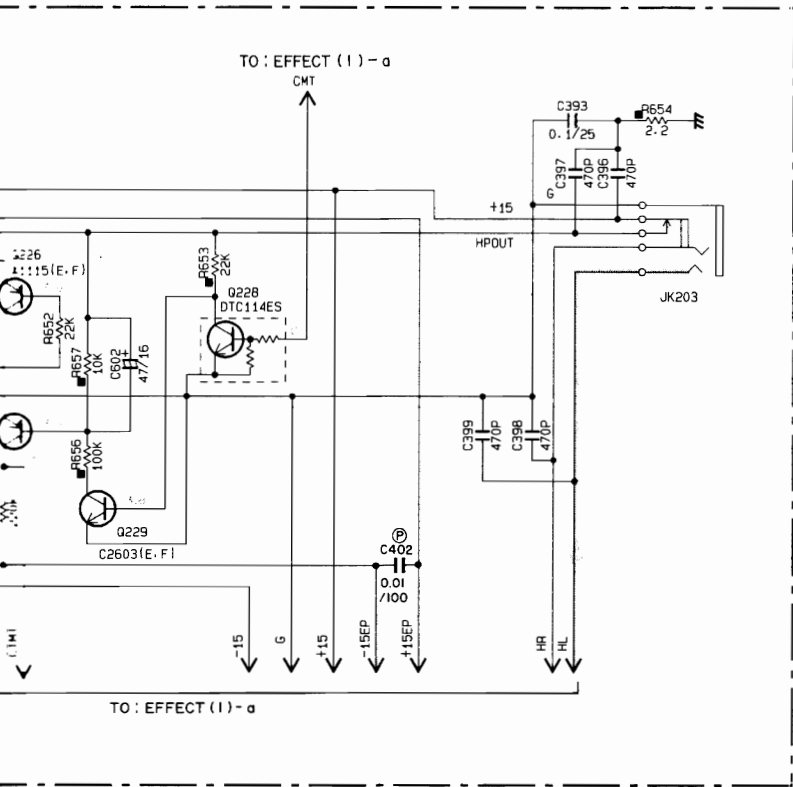

■ SCHEMATIC DIAGRAM (4/4)EFFECT AMP C. B D / E

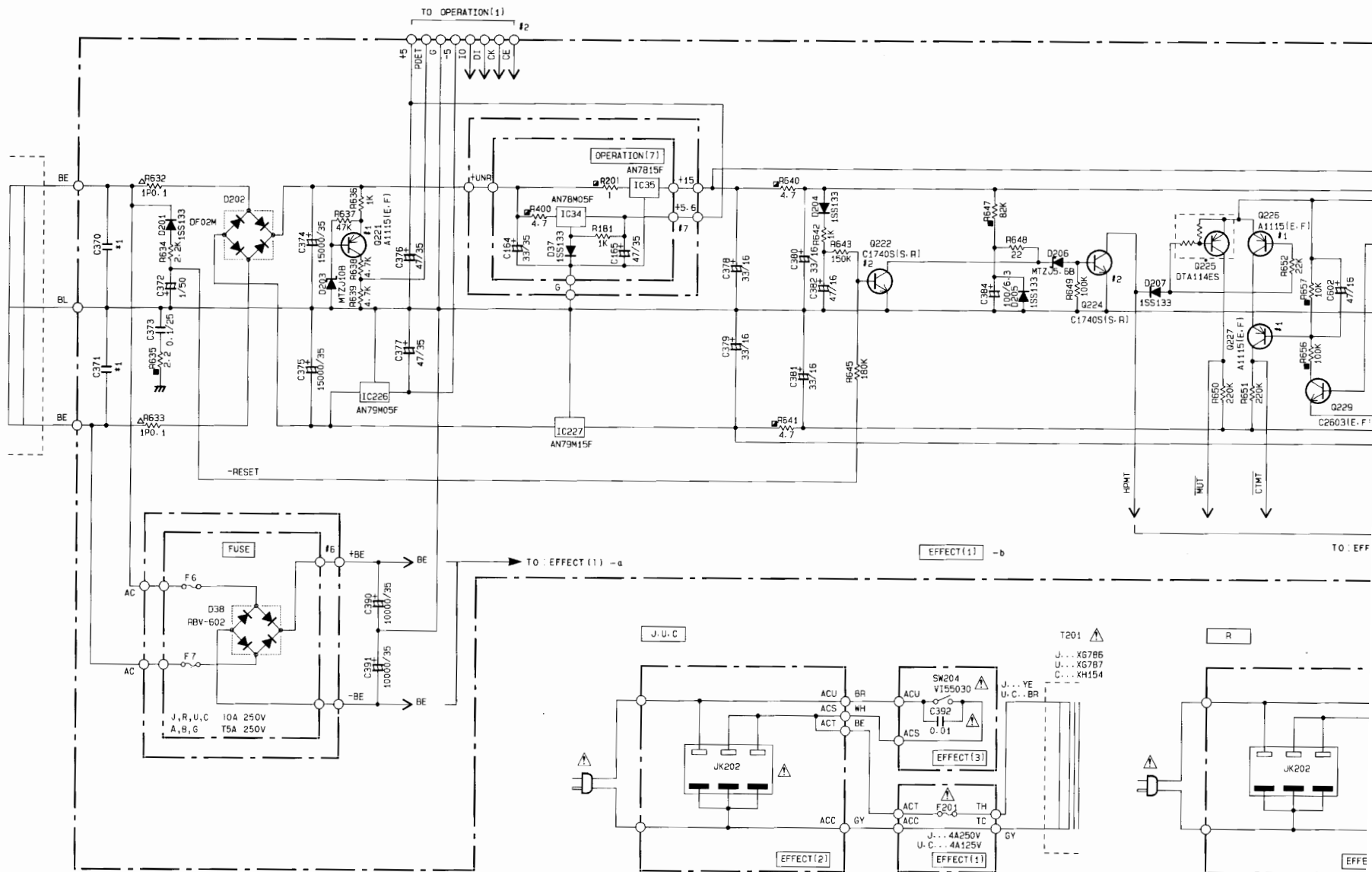
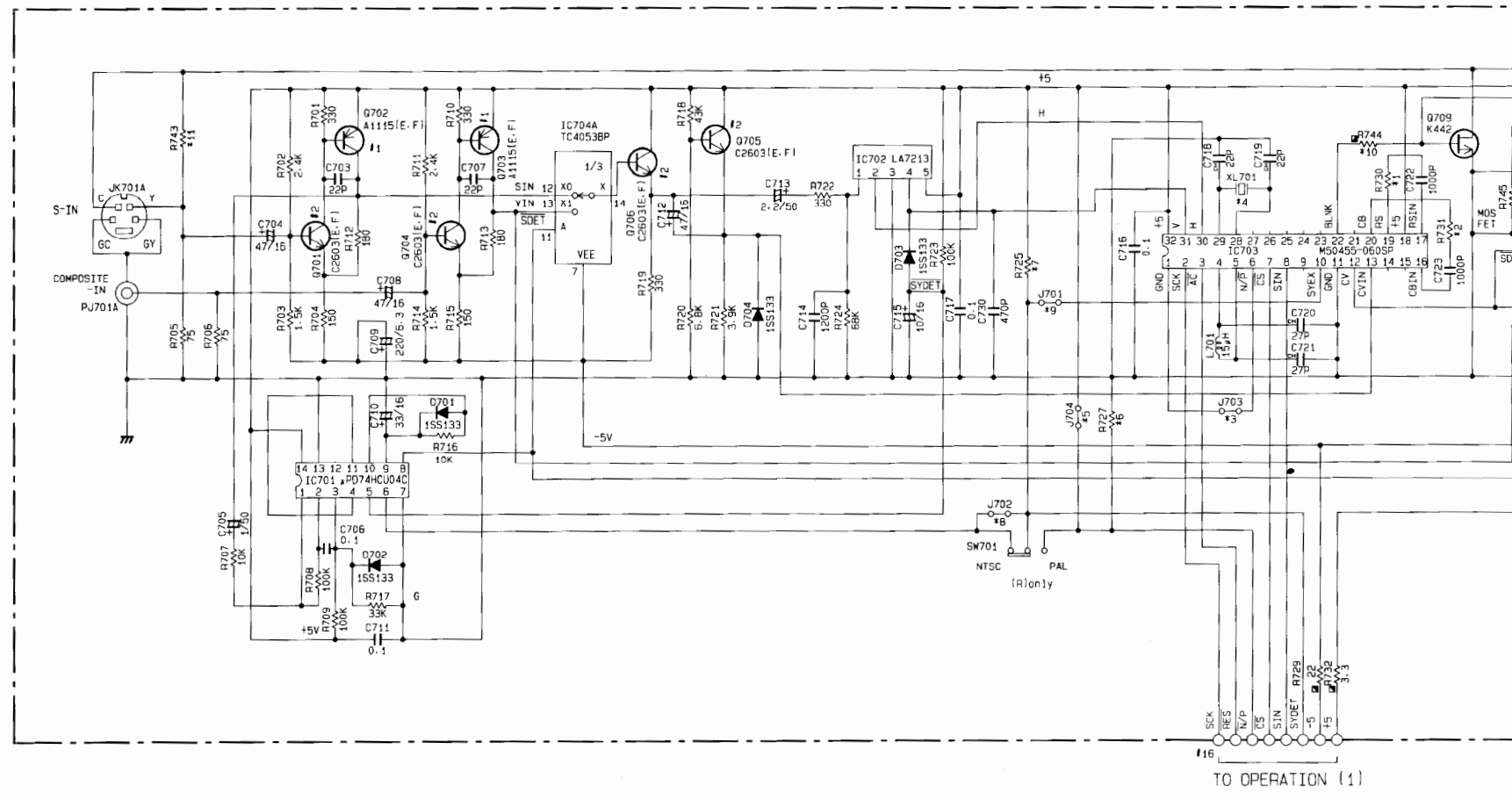

	J	U.C	R	A, B, G
#1	C370-371	0.01B/100		BP 0.47/50
#2	C398-399	470P		4700P

PIN CONNECTION DIAGRAM OF TRANSISTORS, DIODES AND ICs.

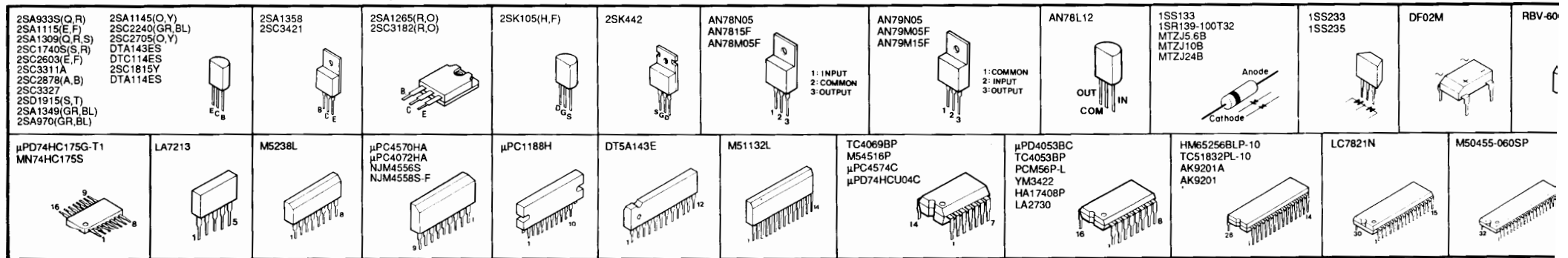

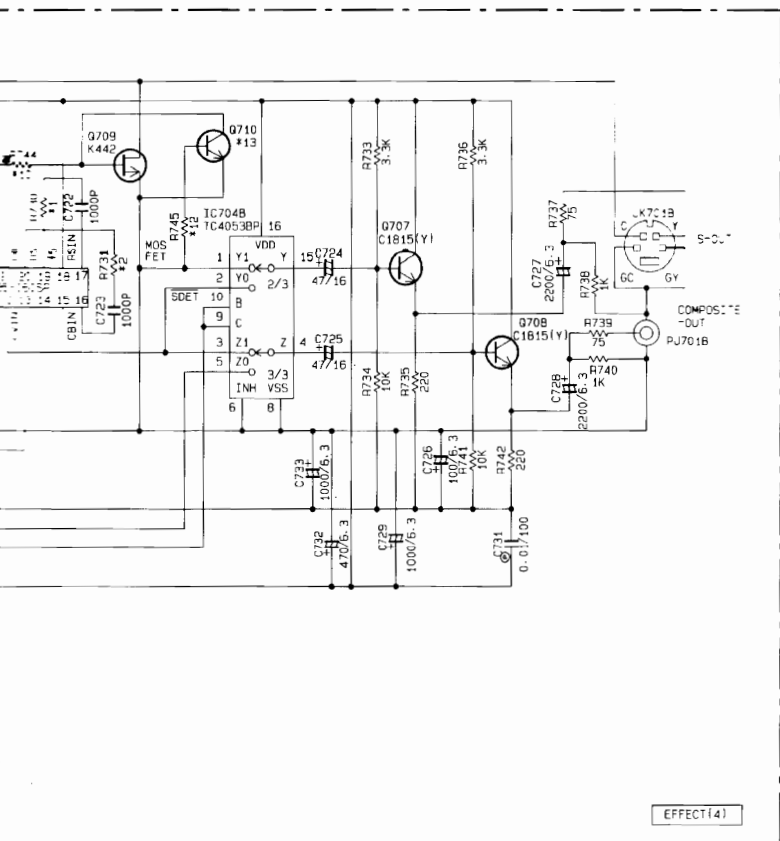

EFFECT(4)

MARK	REMARKS	PARTS NAME	QTY	UNIT	REMARKS
#1		0709	1	PC	MOSEFT
#2		0710	1	PC	MOSEFT
#3		0707	1	PC	MOSEFT
#4		0708	1	PC	MOSEFT
#5		R733	1	PC	3.3K
#6		R735	1	PC	3.3K
#7		R737	1	PC	2200/0.3
#8		R739	1	PC	10K
#9		R740	1	PC	1K
#10		C723	1	PC	1000P
#11		C724	1	PC	47/16
#12		C725	1	PC	47/16
#13		C726	1	PC	1000/0.3
#14		C727	1	PC	1000/0.3
#15		C731	1	PC	0.01/100

REMARKS	PARTS NAME
NO MARK	ELECTROLYTIC CAPACITOR
⊗	TANTALUM CAPACITOR
NO MARK	CERAMIC CAPACITOR
⊙	POLYESTER FILM CAPACITOR
○	POLYSTYRENE FILM CAPACITOR
⊖	MICA CAPACITOR
⊕	POLYPROPYLENE FILM CAPACITOR
⊗	SEMICONDUCTIVE CERAMIC CAPACITOR

REMARKS	PARTS NAME
NO MARK	CARBON FILM RESISTOR (1/4W)
⊗	CARBON FILM RESISTOR (1/2W)
⊖	METAL OXIDE FILM RESISTOR
⊕	METAL FILM RESISTOR
⊗	METAL PLATE RESISTOR
⊕	FIRE PROOF CARBON FILM RESISTOR
⊖	CEMENT MOLDED RESISTOR
⊕	SEMI VARIABLE RESISTOR
⊗	CHIP RESISTOR

Interchangeable Parts at Manufacture-Stage

Mark	Reference Parts Number	Parts Name
#1	G702-703	25A1115(E.F) 25A9335(I.G.R) 25A1309A(I.G.R.S)
#2	G701-704-706	25C2603(E.F) 25C1740(S.R) 25C2603(E.F) 25C331A(I.G.R.S)

NOTICE
 (J)..... Japanese model
 (U)..... U.S.A model
 (C)..... Canadian model
 (A)..... Australian model
 (G)..... European model
 (B)..... British model
 (R)..... General model
 (P)..... RP model

EFFECT	LAST NO.	UN LISTED NO.
C	733	
R	745	
G	710	
D	724	
IC	724	

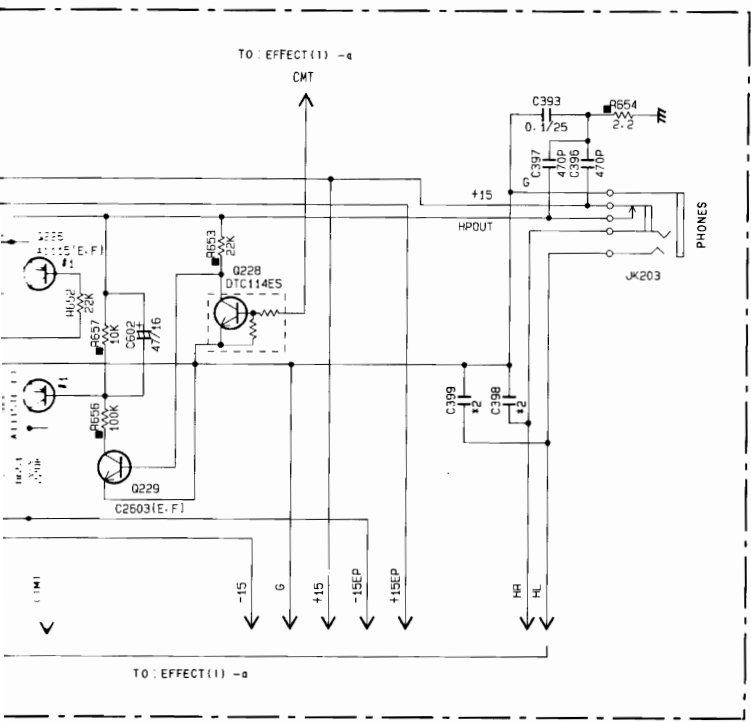

NOTICE
 (J)..... Japanese model
 (U)..... U.S.A model
 (C)..... Canadian model
 (A)..... Australian model
 (G)..... European model
 (B)..... British model
 (R)..... General model
 (P)..... RP model

Interchangeable Parts at Manufacture-Stage

Mark	Reference Parts Number	Parts Name
#1	G221-226-227	25A1115(E.F) 25A9335(I.G.R) 25A1309A(I.G.R.S)
#2	G222-224	25C1740(S.R) 25C2603(E.F) 25C331A(I.G.R.S)

REMARKS	PARTS NAME
NO MARK	CARBON FILM RESISTOR (1/8W)
⊗	CARBON FILM RESISTOR (1/4W)
⊖	METAL OXIDE FILM RESISTOR
⊕	METAL FILM RESISTOR
⊗	METAL PLATE RESISTOR
⊕	FIRE PROOF CARBON FILM RESISTOR
⊖	CEMENT MOLDED RESISTOR
⊕	SEMI VARIABLE RESISTOR
⊗	CHIP RESISTOR

REMARKS	PARTS NAME
NO MARK	ELECTROLYTIC CAPACITOR
⊗	TANTALUM CAPACITOR
NO MARK	CERAMIC CAPACITOR
⊙	POLYESTER FILM CAPACITOR
○	POLYSTYRENE FILM CAPACITOR
⊖	MICA CAPACITOR
⊕	POLYPROPYLENE FILM CAPACITOR
⊗	SEMICONDUCTIVE CERAMIC CAPACITOR

EFFECT	LAST NO.	UN LISTED NO.
C	402 622	
R	400 657	
Q	229	
D	207	
IC	227	

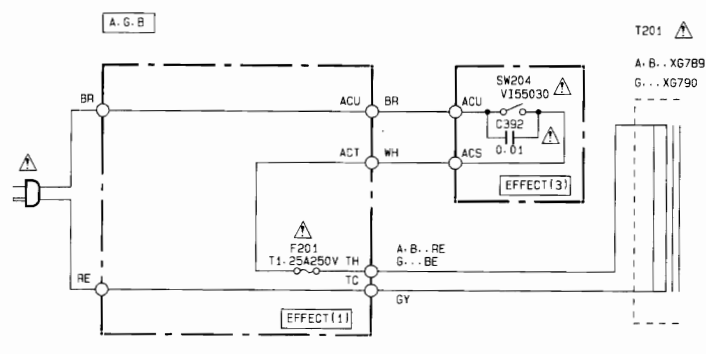
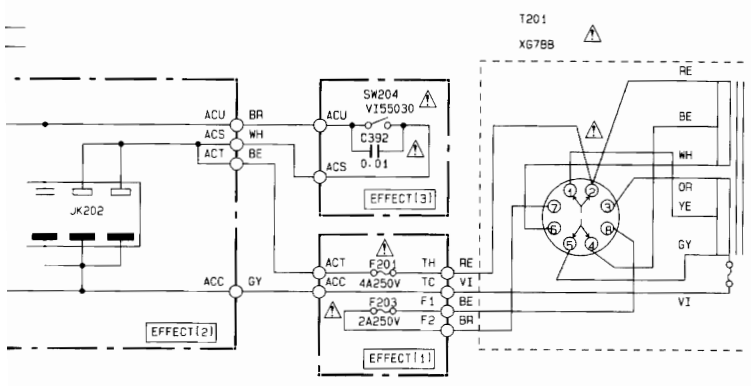

RBV-602	4D4B41	μPC4570G2-T1	μPD74HC00G-T1 μPD74HCU04G-T1 MN74HCU04S μPD74HC74G-T1 μPD74HC393G-T1 MN74HC393S μPD4053G-T1
M50455-060SP	YM3413	LA2770	HD63B01Y0RL37P M50747-B87

* All voltage are measured with a 10MΩ/DC electric volt meter.
 * Components having special characteristics are marked Δ and must be replaced with parts having specifications equal to those originally installed.
 * Schematic diagram is subject to change without notice.

PRINTED CIRCUIT BOARD (Foil side)

Note) 文字面 : Component side

OPERATION C. B B (1)

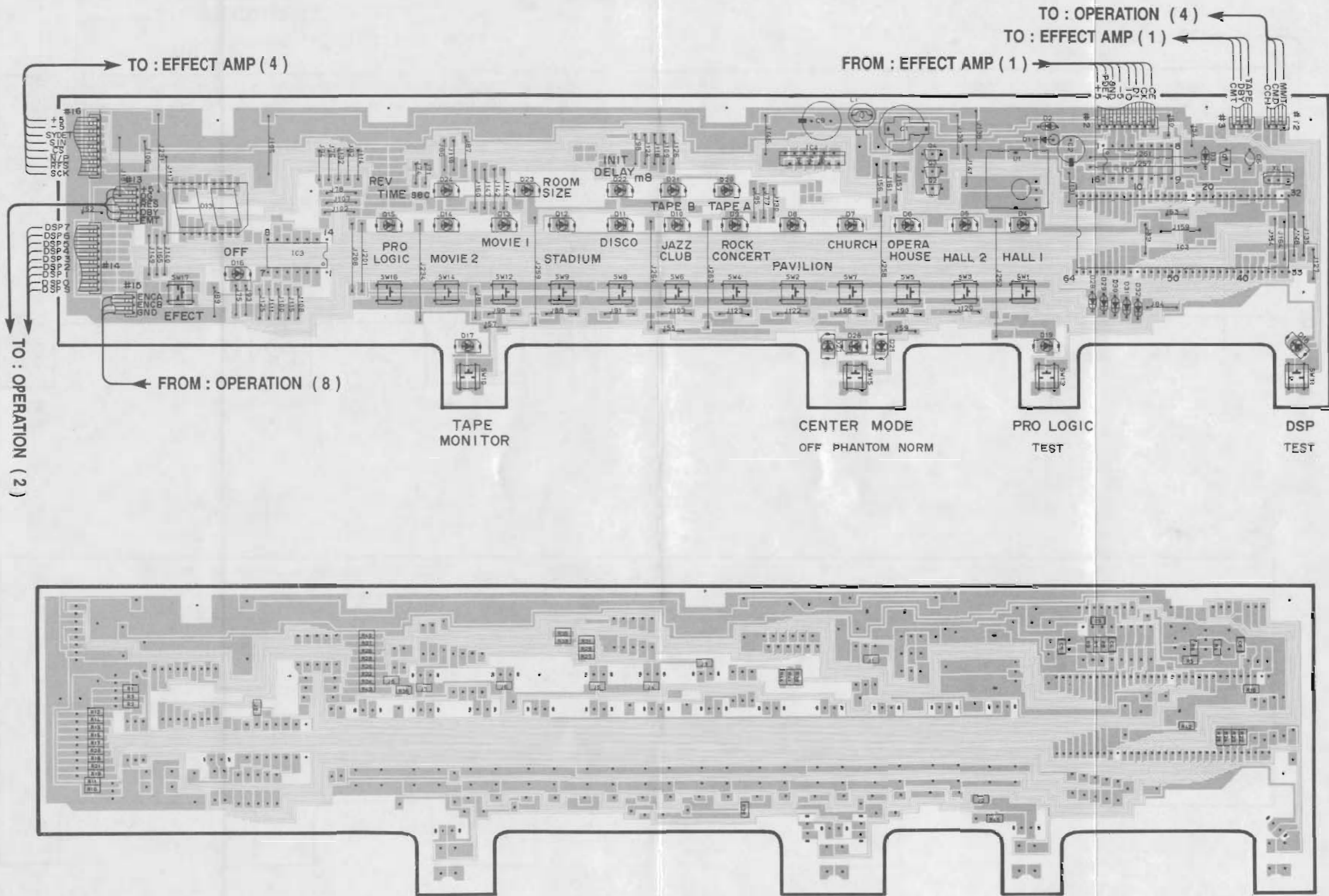

PRINTED CIRCUIT BOARD (Foil side)

Note) 文字面 : Component side

OPERATION C. B C / D (1)

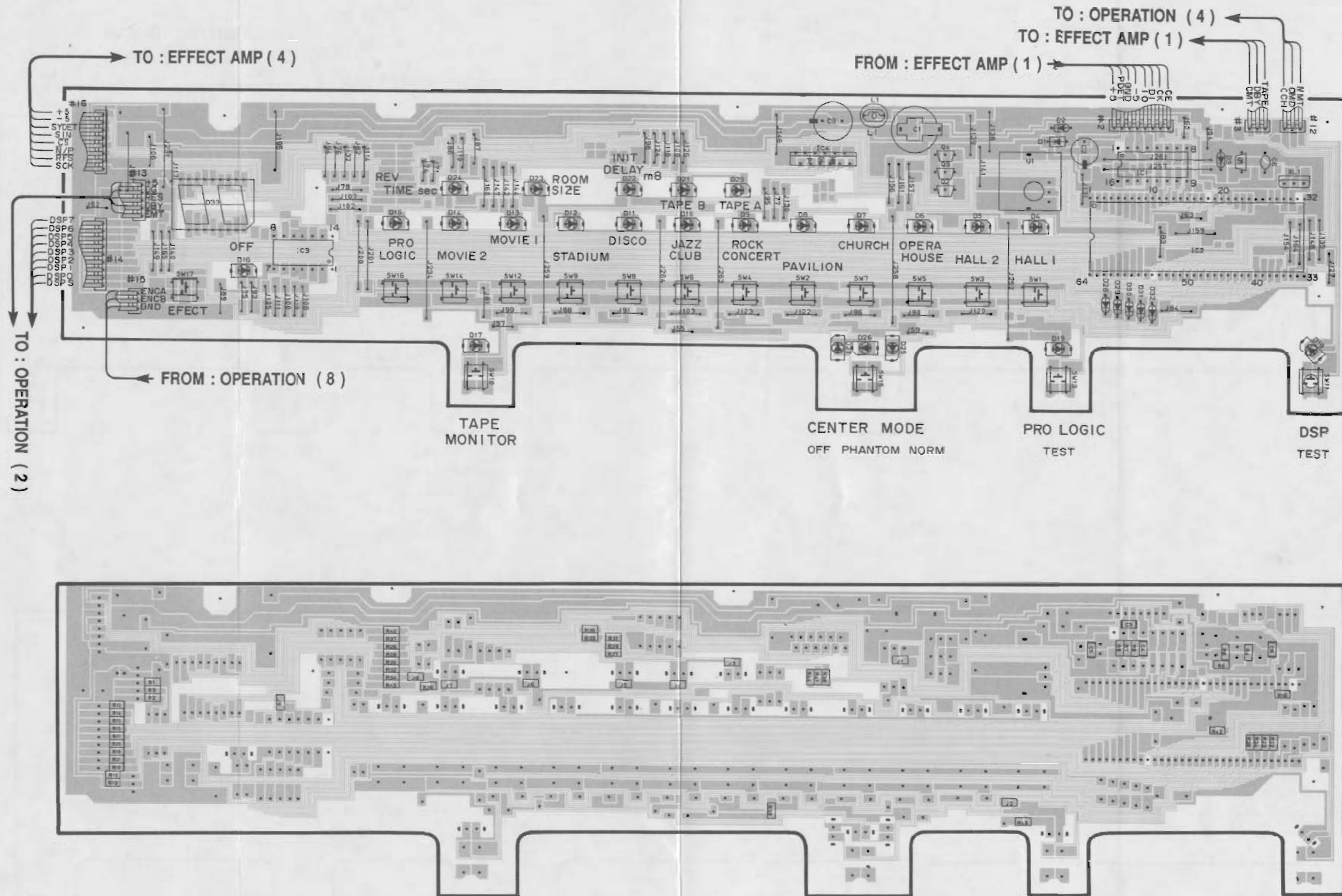

PRINTED CIRCUIT BOARD (Foil side)

Note) 文字面 : Component side

OPERATION C. B B (4)

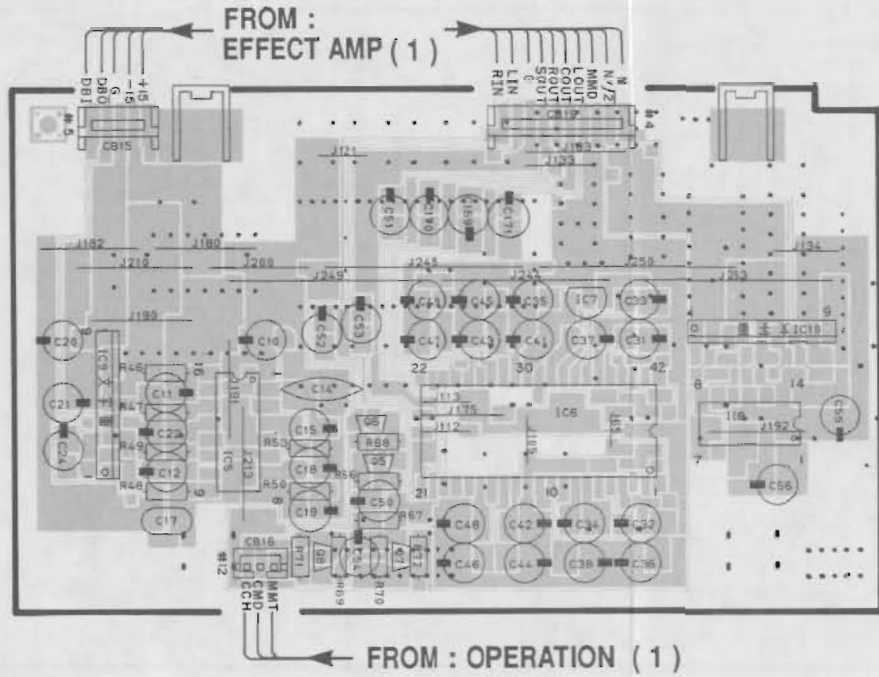

OPERATION C. B C/D (4)

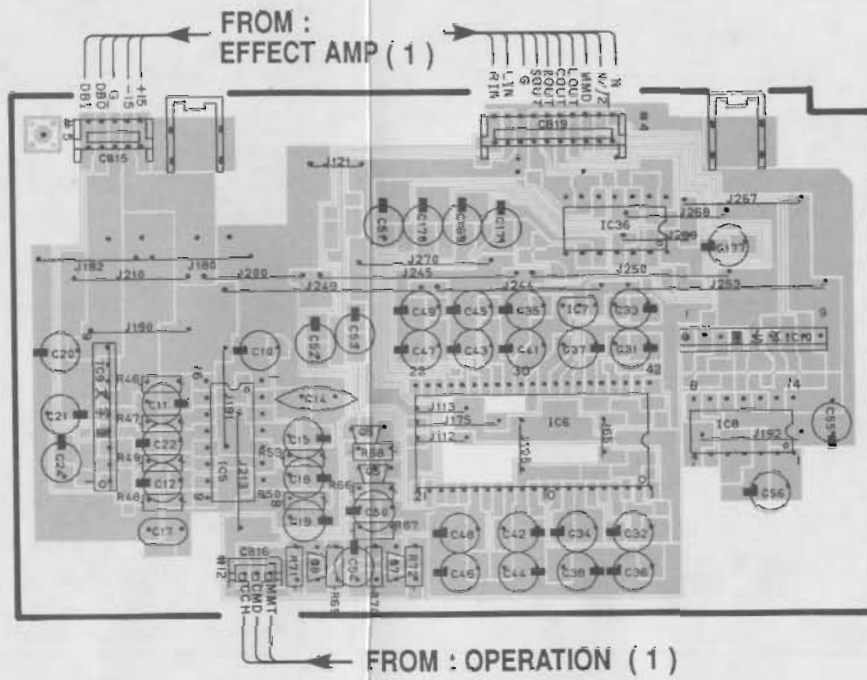

OPERATION C. B B (5)

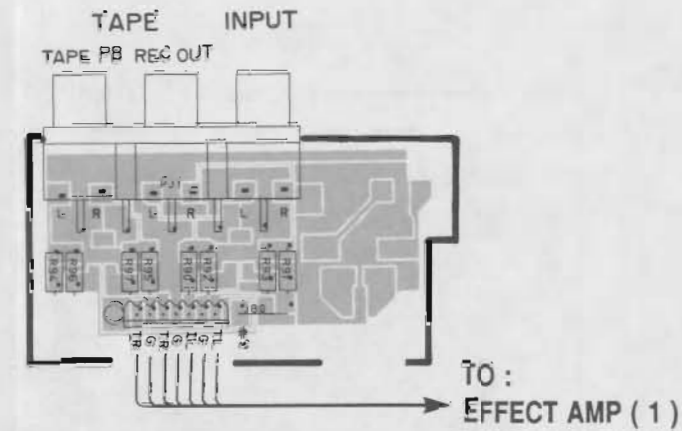

OPERATION C. B C/D (5)

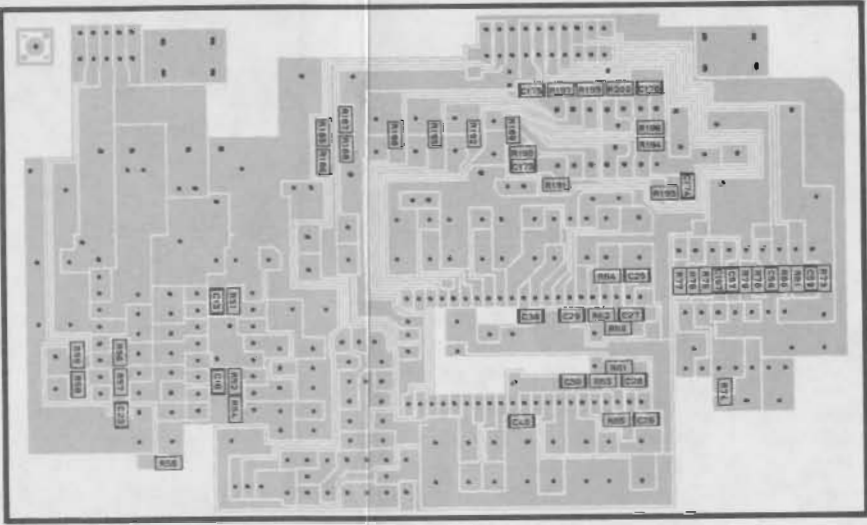
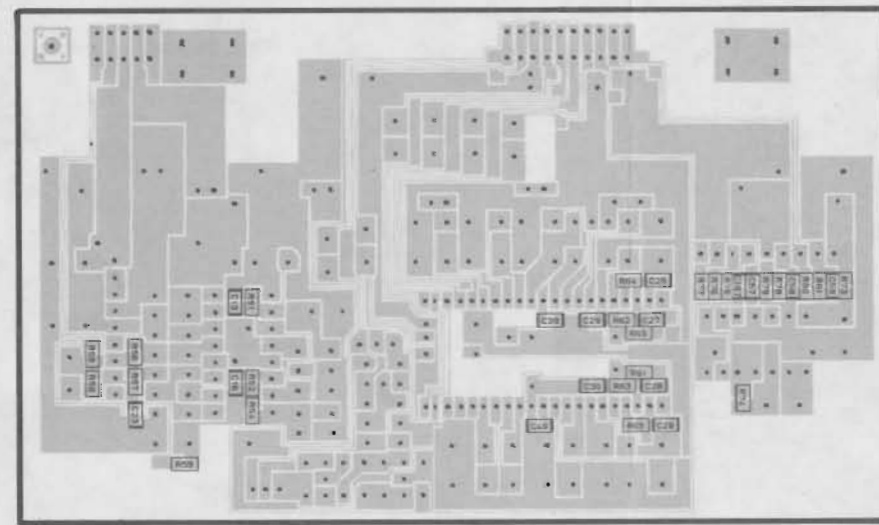
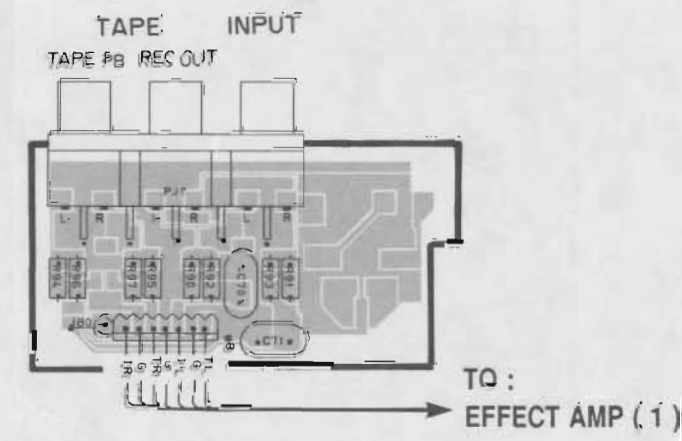

PRINTED CIRCUIT BOARD (Foil side)

Note) 文字面 : Component side

OPERATION C. B (3)

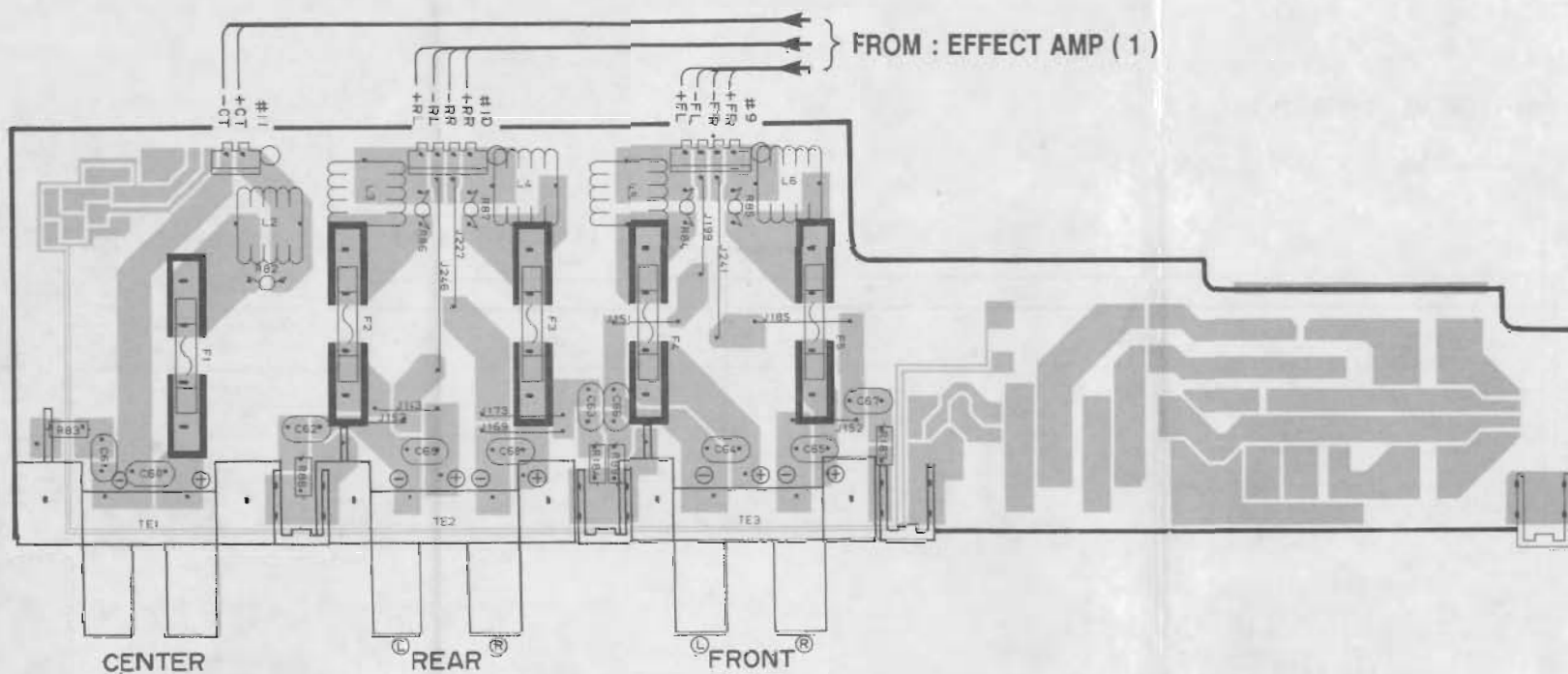

FUSE C. B

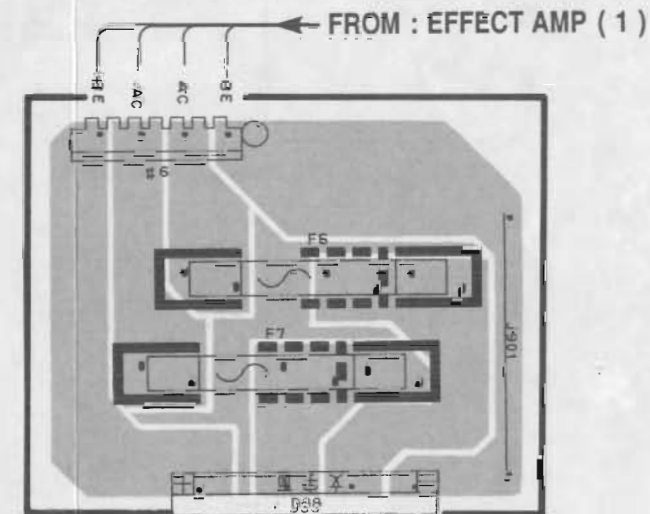

OPERATION C. B (8)

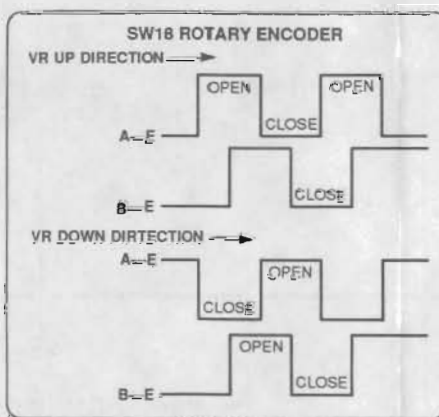
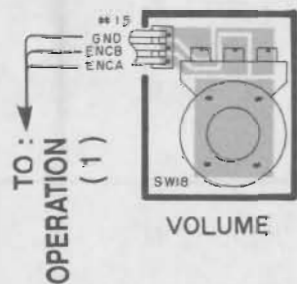

OPERATION C. B B (7)

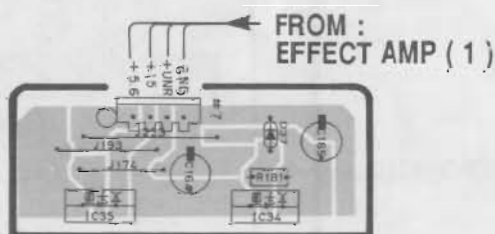

OPERATION C. B C (7)

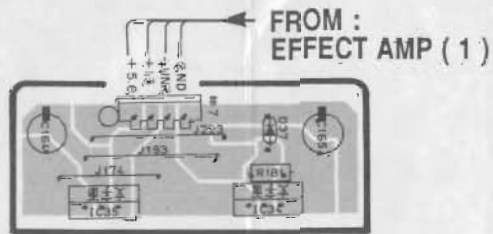

OPERATION C. B D (7)

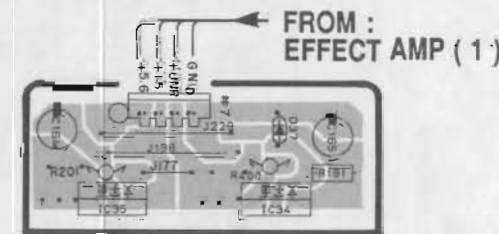

PRINTED CIRCUIT BOARD (Foil side)

Note) 文字面 : Component side

EFFECT AMP C. B [C] (1)

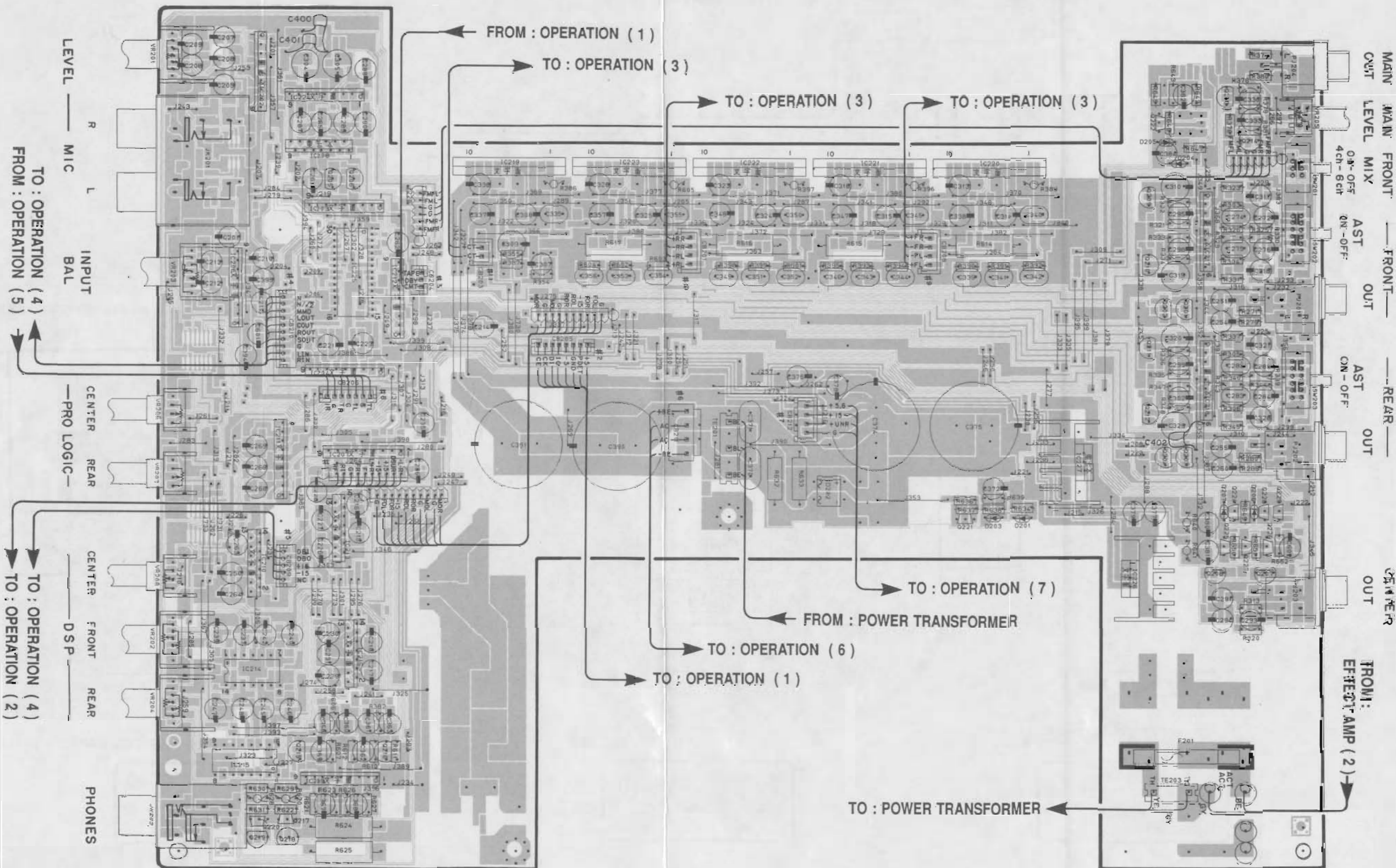

■ PRINTED CIRCUIT BOARD (Foil side)

Note) 文字面 : Component side

EFFECT AMP C. B C (1)

1

2

3

4

5

6

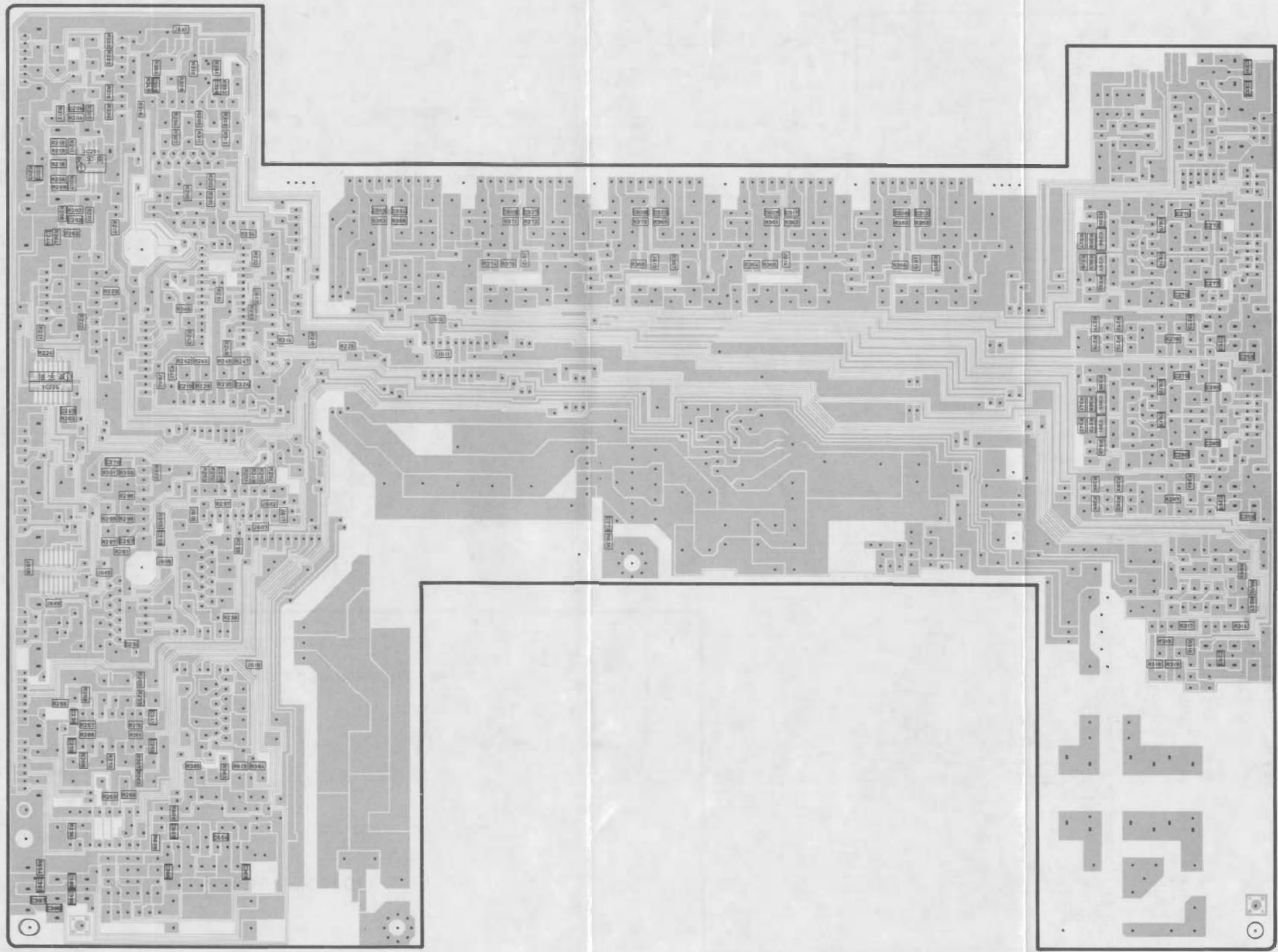

■ PRINTED CIRCUIT BOARD (Foil side)

Note) 文字面 : Component side

EFFECT AMP C. B D (1)

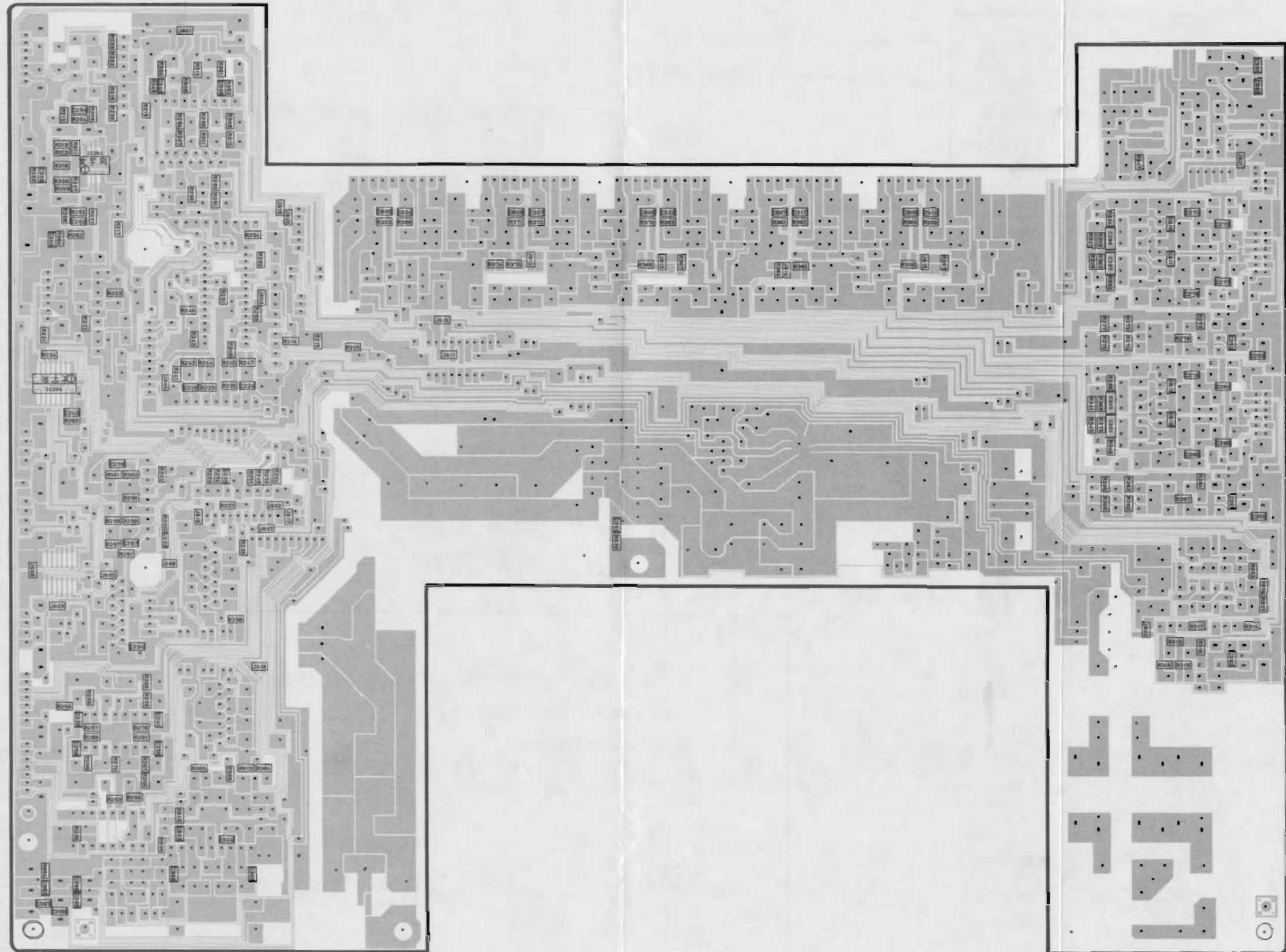

PRINTED CIRCUIT BOARD (Foil side)

Note) 文字面 : Component side

EFFECT AMP C. B E (1)

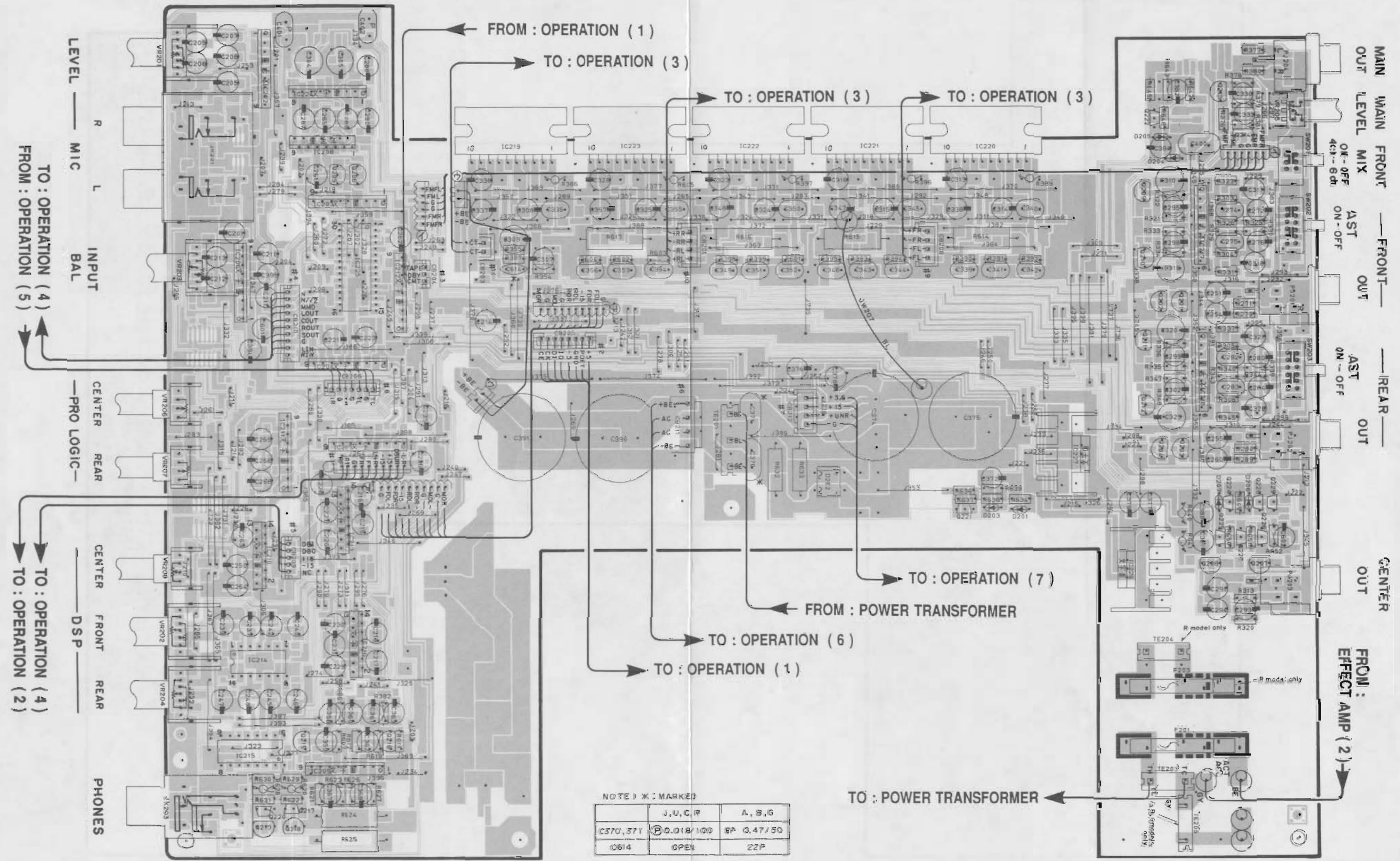

NOTE) X: MARKED

	J, U, C, P	A, B, G
C370, 371	0.018/100	5P 0.47/50
C614	OPEN	22P

■ PRINTED CIRCUIT BOARD (Foil side)

Note) 文字面 : Component side

EFFECT AMP C. B E (1)

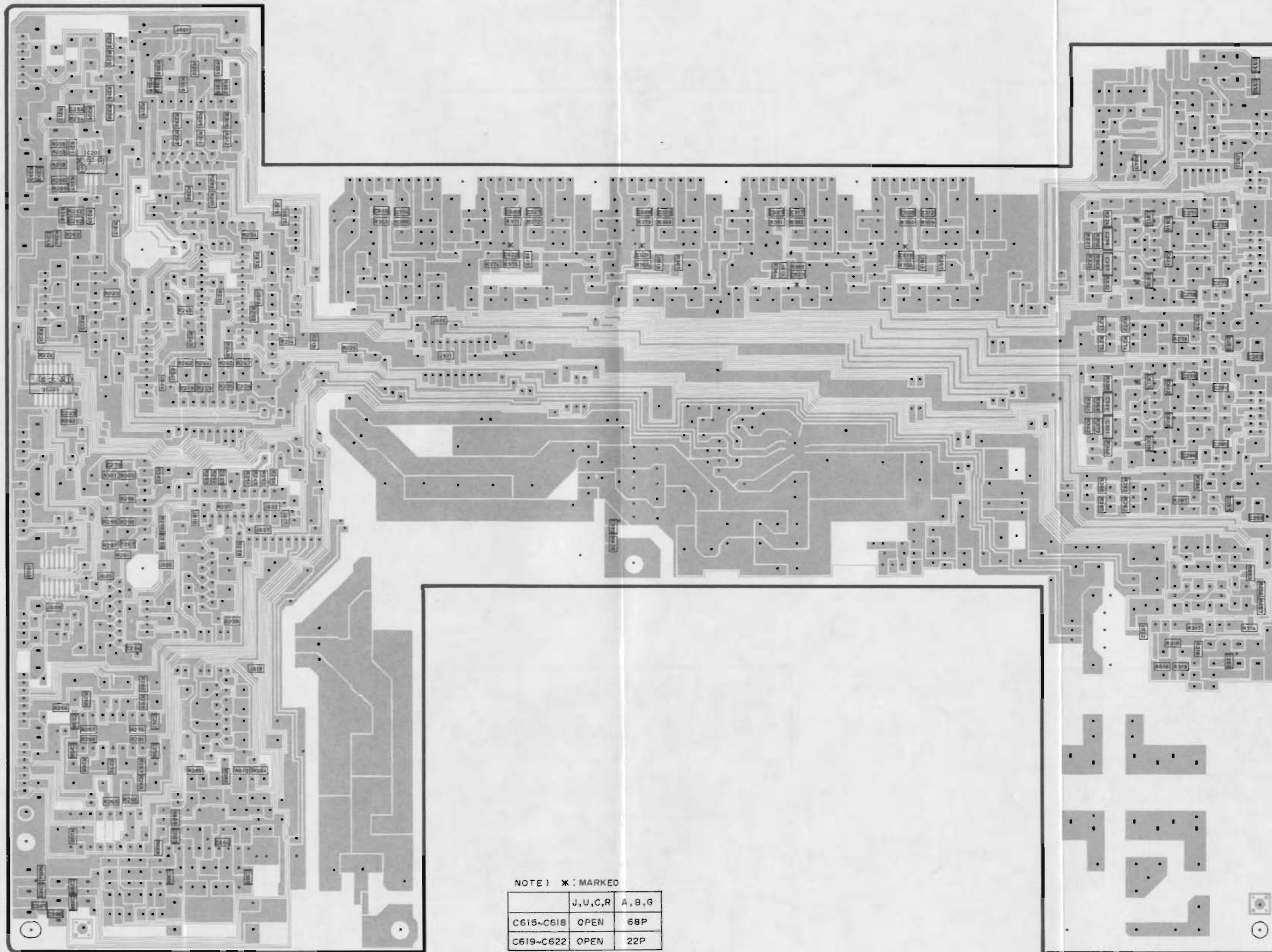

NOTE) * : MARKED

	J, U, C, R	A, B, G
C615~C618	OPEN	68P
C619~C622	OPEN	22P

PRINTED CIRCUIT BOARD (Foil side)

Note) 文字面 : Component side

EFFECT AMP C. B C (4)

EFFECT AMP C. B D (4)

EFFECT AMP C. B E (4)

J, U, C, A, B, G models

J, U, C, A, B, G models

J, U, C, A, B, G models

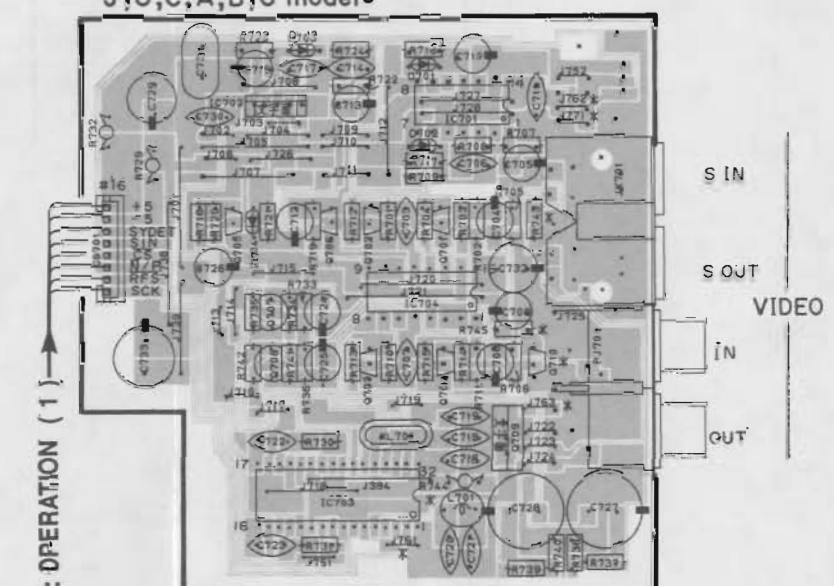
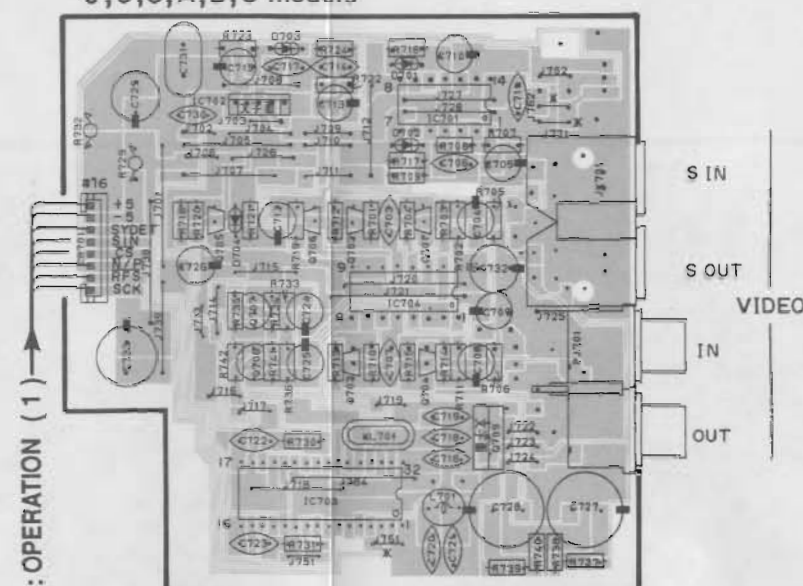
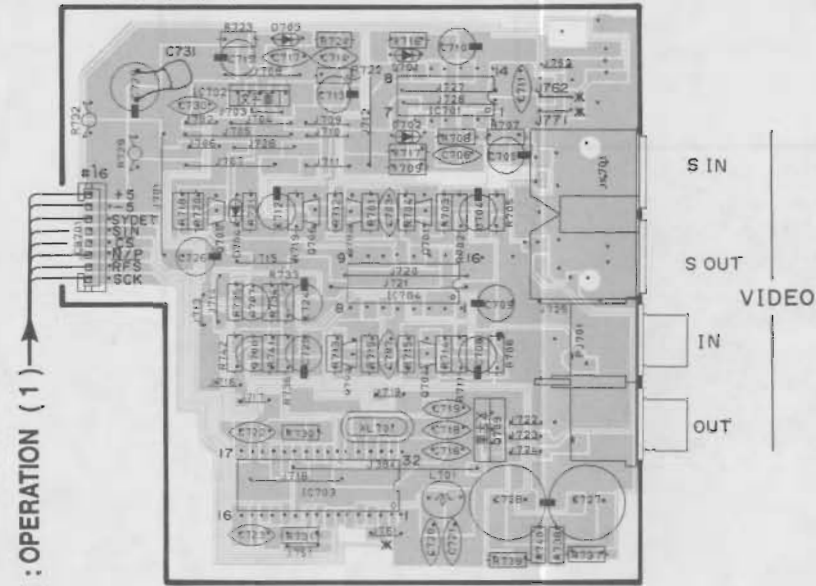

NOTE) X: MARKED

	J, U, C	A, B, G
J761, 762	OPEN	SET
J771	SET	OPEN

NOTE) X: MARKED

	J, U, C	A, B, G
J761, 762	OPEN	SET
J771	SET	OPEN

NOTE) X: MARKED

	J, U, C	A, B, G
J761 ~ 763	OPEN	SET
J771	SET	OPEN
R743	OPEN	2.2K
R744	OPEN	100
R745	OPEN	1K
Q710	OPEN	SET

R model

R model

R̄ model

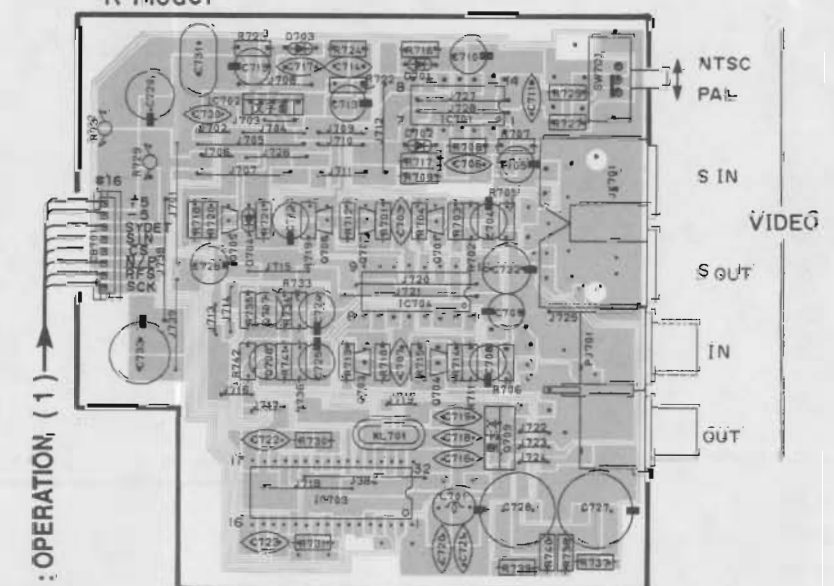
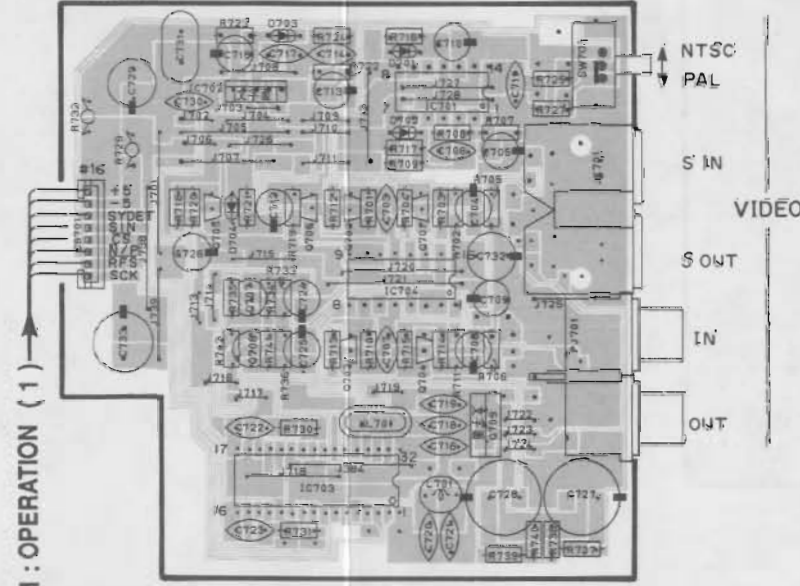
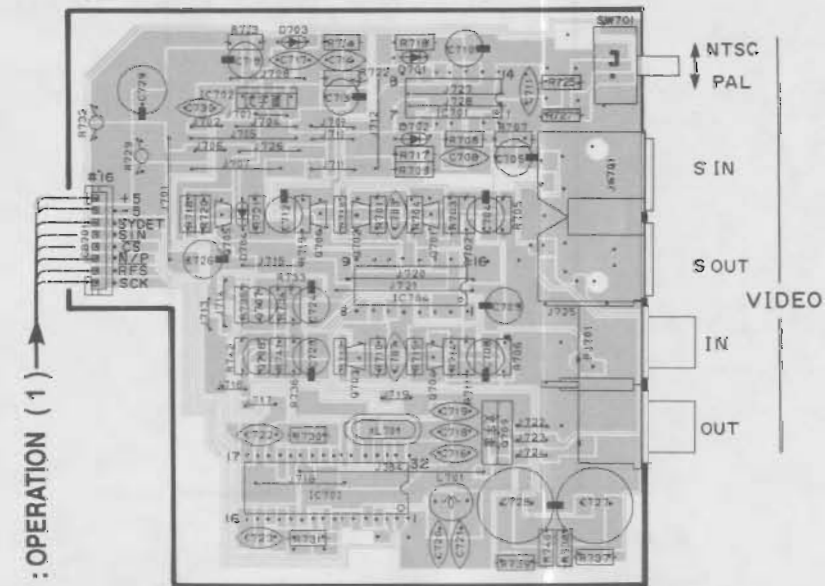

PRINTED CIRCUIT BOARD (Foil side)

Note) 文字面 : Component side

● U, C models

● A, B, G models

EFFECT AMP C. B (1)

EFFECT AMP C. B (2)

EFFECT AMP C. B (3)

EFFECT AMP C. B (1)

EFFECT AMP C. B (3)

CENTER
OUT

AC OUTLETS
ONSWITCHED SWITCHED

CENTER
OUT

FROM : EFFECT AMP (1)

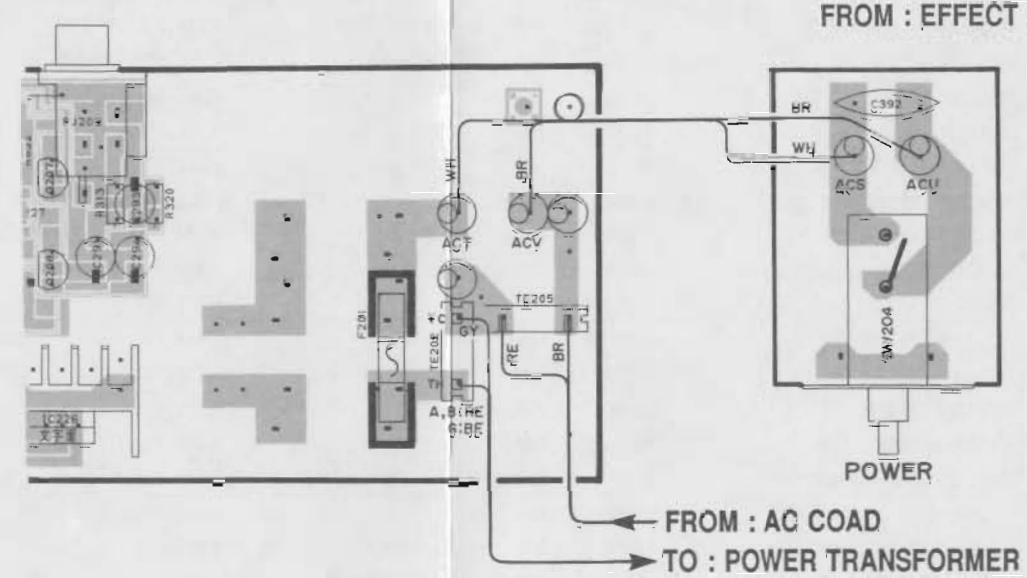
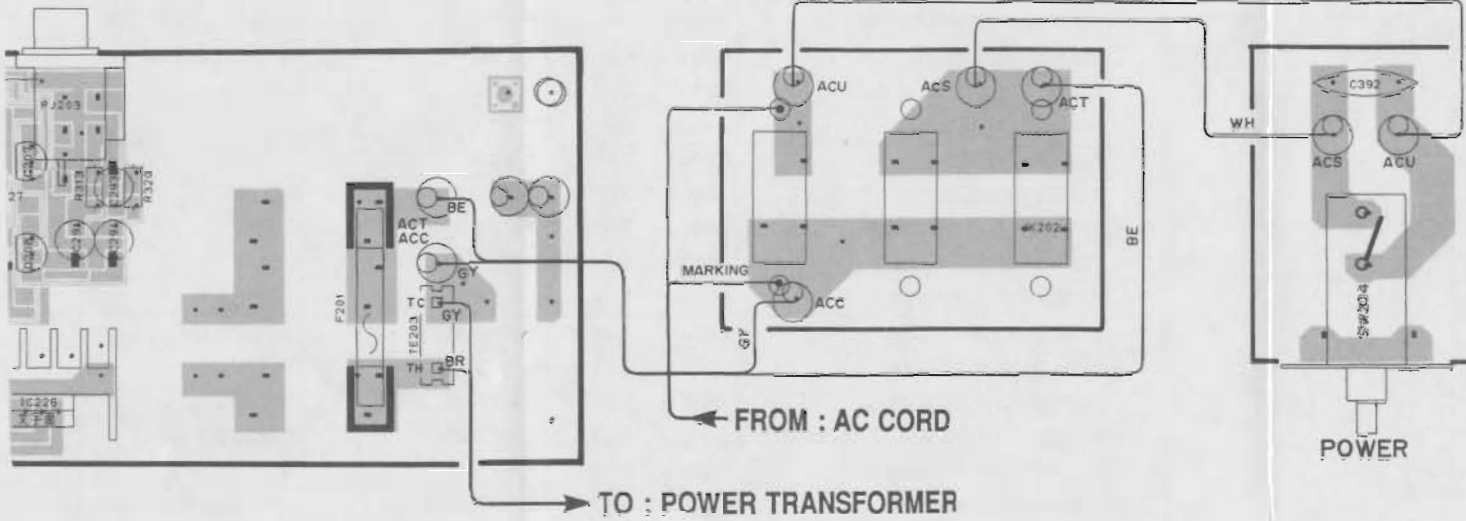

● R model

EFFECT AMP C. B (1)

EFFECT AMP C. B (2)

EFFECT AMP C. B (3)

CENTER
OUT

AC OUTLETS
ONSWITCHED SWITCHED

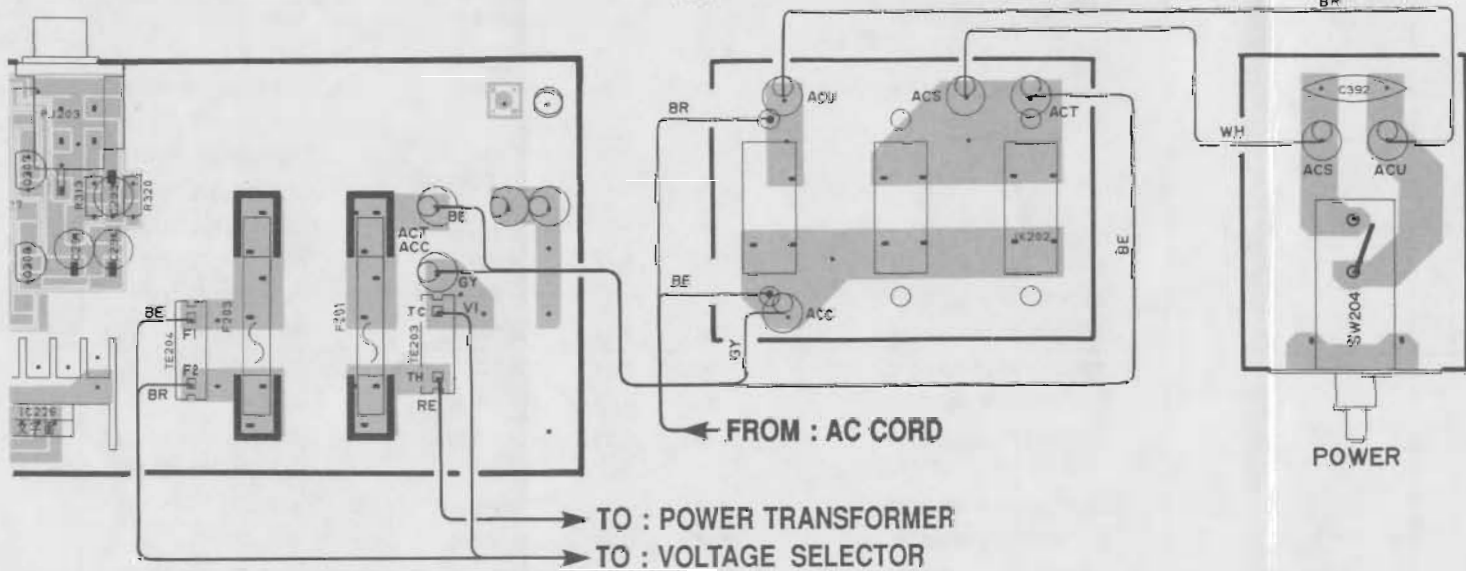

PARTS LIST

■ ELECTRICAL PARTS

■ WARNING

Components having special characteristics are marked Δ and must be replaced with parts having specifications equal to those originally installed.

● Carbon resistors (1/6W or 1/4W) are not included in the ELECTRICAL PARTS List. For the parts No. of the carbon resistors, refer to P. 66.

Ref. NO.	PART NO.	Description	部 品 名	Remarks	Markets	ランク
+	V1184300	EFFECT CIRCUIT BOARD	エフェクトシート		U,C	
+	V1184600	EFFECT CIRCUIT BOARD	エフェクトシート		A,B,G	
+	V1608800	EFFECT CIRCUIT BOARD	エフェクトシート		J	
+	V1184500	EFFECT CIRCUIT BOARD	エフェクトシート		R	
	UA254390	MYLAR FILM CAP 0.039 μ F 50V	マイラーコン	C341,343,351,353		
	UA254470	MYLAR FILM CAP 0.047 μ F 50V	マイラーコン	C335,340,345,350,355		
	UA254560	MYLAR FILM CAP 0.056 μ F 50V	マイラーコン	C274,275,282,283		
	UA254680	MYLAR FILM CAP 0.068 μ F 50V	マイラーコン	C339,346,349,356		
	UA555390	MYLAR FILM CAP 0.39 μ F 50V	マイラーコン	C342,344,352,354		
	UT654180	POLYPROPYLEN CAP 0.018 μ F 100V	PPコン	C370,371	J,U,C,R	
	UK565470	ELECTROLYTIC CAP 0.47 μ F 50V	B P ケミコン	C370,371	A,B,G	
	FG211220	CERAMIC CAP 22PF 50V	セラコン	C703,707		
	FG211220	CERAMIC CAP 22PF 50V	セラコン	C614	A,B,G	
	FG212470	CERAMIC CAP 470PF 50V	セラコン	C730		
	FG213100	CERAMIC CAP 1000PF 50V	セラコン	C722,723		
	FG713120	CERAMIC CAP 1200PF 50V	セラコン	C714		
	VA761000	CERAMIC CAP 22PF 50V	セラコン	C718,719		
	VA761100	CERAMIC CAP 27P 50V	セラコン	C720,721		
	VF611200	CERAMIC CAP 0.1 μ F 50V	積層セラコン	C711,716,717		
	UD111220	CHIP CERAMIC CAP 22PF 50V	チップセラコン	C619-622	A,B,G	
+	V1226400	CHIP CERAMIC CAP 68PF 50V	チップセラコン	C312,317,322,327,334		
+	V1226400	CHIP CERAMIC CAP 68PF 50V	チップセラコン	C615-618	A,B,G	
+	VH531900	CHIP CERAMIC CAP 100PF 50V	チップ積層セラコン	C202,204,219,224,225, 256,258,267,303,306, 270,603,604,610-613	238,241, 366,369,	
+	VH531900	CHIP CERAMIC CAP 100PF 50V	チップ積層セラコン	C605-609	J,U,C,R	
+	V1227600	CHIP CERAMIC CAP 220PF 50V	チップセラコン	C605-609	A,B,G	
+	V1227600	CHIP CERAMIC CAP 220PF 50V	チップセラコン	C252,253,257,259,292,	331,332	
+	VH058000	CHIP CERAMIC CAP 470PF 50V	チップ積層セラコン	C369-397		
+	VH058000	CHI CERAMIC CAP 470PF 50V	チップ積層セラコン	C398,399	J,U,C,R	
+	V1230900	CHIP CERAMIC CAP 4700PF 50V	積層チップセラコン	C398,399	A,B,G	
+	V1230100	CHIP CERAMIC CAP 2200PF 50V	積層チップセラコン	C271,278,279,286		
+	V1231100	CHIP CERAMIC CAP 5600PF 50V	積層チップセラコン	C273,277,281,285		
+	V1231300	CHIP CERAMIC CAP 6800PF 50V	積層チップセラコン	C234		
+	V1231700	CHIP CERAMIC CAP 0.01 μ F 50V	積層チップセラコン	C233		
+	VD499400	CHIP CERAMIC CAP 0.1 μ F 25V	チップ積層セラコン	C203,243,244,373,393		
+	UD114820	CHIP CERAMIC CAP 0.082 μ F 50V	チップ積層セラコン	C296,297,300,301		
+	Fi414100	CERAMIC CAP 0.01 μ F	スパークキラーコン	C392		Δ
+	UH157100	ELECTROLYTIC CAP 10 μ F 35V	ケミコン	C313,316,323,326,347 336-338,348,357		
	VG286200	ELECTROLYTIC CAP 100 μ F 6.3V	ケミコン	C239,240,246,247,268, 367,368,384,726		
	V1844200	ELECTROLYTIC CAP 47 μ F 35V	ケミコン	C308,314,315,324,325, 376,377		
	VG286300	ELECTROLYTIC CAP 220 μ F 6.3V	ケミコン	C709		
	VG286500	ELECTROLYTIC CAP 470 μ F 6.3V	ケミコン	C732		
	VG286600	ELECTROLYTIC CAP 1000 μ F 6.3V	ケミコン	C729,733		
	VG287200	ELECTROLYTIC CAP 10 μ F 16V	ケミコン	C287,289,307,311,318, 321,328,715,214		
	VG287400	ELECTROLYTIC CAP 33 μ F 16V	ケミコン	C201,205-213,215-218,	221,223,	

*New Parts (新規部品)

ランク : Japan only

Ref. NO.	PART NO.	Description	部 品 名	Remarks	Markets	ランク
	VG287400	ELECTROLYTIC CAP 33 μ F 16V	ケミコン	226-231,235-273,242, 251,254,255,260-266, 284,290,291,294,304, 330,333,358-363,394, 378-381,395,601,710	245,250, 269,288, 305,	
	VG287500	ELECTROLYTIC CAP 47 μ F 16V	ケミコン	C382,704,708,712,724,	725,602	
	VG287700	ELECTROLYTIC CAP 220 μ F 16V	ケミコン	C309,310,319,320,329		
	VG290100	ELECTROLYTIC CAP 0.22 μ F 50V	ケミコン	C272,276,280,284		
	VG290500	ELECTROLYTIC CAP 1 μ F 50V	ケミコン	C372,705,293,295,298,	299,302	
	VG290600	ELECTROLYTIC CAP 2.2 μ F 50V	ケミコン	C713		
	UH119220	ELECTROLYTIC CAP 2200 μ F 6.3V	ケミコン	C727,728		
+	Vi349000	ELECTROLYTIC CAP 10000 μ F 35V	ブロックケミコン	C390,391		
+	Vi349100	ELECTROLYTIC CAP 15000 μ F 35V	ブロックケミコン	C374,375		
	VB115600	COIL EL0606RA 15 μ H	固定コイル	L701		
	RD250000	CHIP RESISTOR 0 Ω 0.1W	チップ抵抗	J601-616,617,618		
	RD253220	CHIP RESISTOR 2.2 Ω 0.1W	チップ抵抗	R203,635,634		
+	RD254220	CHIP RESISTOR 22 Ω 0.1W	チップ抵抗	R209,210		
+	RD255100	CHIP RESISTOR 100 Ω 0.1W	チップ抵抗	R201,205		
+	RD255220	CHIP RESISTOR 220 Ω 0.1W	チップ抵抗	R221,224		
+	RD255330	CHIP RESISTOR 330 Ω 0.1W	チップ抵抗	R215		
+	RD255470	CHIP RESISTOR 470 Ω 0.1W	チップ抵抗	R237-239,258,259,267,	268,298	
+	RD256100	CHIP RESISTOR 1K Ω 0.1W	チップ抵抗	R290,293		
+	RD256160	CHIP RESISTOR 1.6K Ω 0.1W	チップ抵抗	R230,233,350,351		
+	RD256200	CHIP RESISTOR 2K Ω 0.1W	チップ抵抗	R216,217,219,220,242,	247	
+	RD256220	CHIP RESISTOR 2.2K Ω 0.1W	チップ抵抗	R206,213,229,235,241,	248,255,	
	RD256270	CHIP RESISTOR 2.7K Ω 0.1W	チップ抵抗	272,277,283,286,315, 363,368,373,307,311	318,358,	
	RD256470	CHIP RESISTOR 4.7K Ω 0.1W	チップ抵抗	R225,263,264,300,257, 288,297	276,281,	
	RD256560	CHIP RESISTOR 5.6K Ω 0.1W	チップ抵抗	R218,249-254,261,262,	308,312	
	RD256820	CHIP RESISTOR 8.2K Ω 0.1W	チップ抵抗	R208,212		
	RD257100	CHIP RESISTOR 10K Ω 0.1W	チップ抵抗	R301,302		
	RD257100	CHIP RESISTOR 10K Ω 0.1W	チップ抵抗	R214,256,260,265,270, 278,282,284,285,287,	273-275, 291,292,	
	RD257110	CHIP RESISTOR 11K Ω 0.1W	チップ抵抗	294-296,309,310,314,	316,317,	
	RD257110	CHIP RESISTOR 11K Ω 0.1W	チップ抵抗	319,327,328,341,342, 383-385,613,243,246,	657,608, 609	
+	RD257120	CHIP RESISTOR 12K Ω 0.1W	チップ抵抗	R207,211,349,352		
+	RD257220	CHIP RESISTOR 22K Ω 0.1W	チップ抵抗	R324,332,338,346		
+	RD257470	CHIP RESISTOR 47K Ω 0.1W	チップ抵抗	R353,360,361,370,371,	653	
	RD257820	CHIP RESISTOR 82K Ω 0.1W	チップ抵抗	R202,204		
	RD258100	CHIP RESISTOR 100K Ω 0.1W	チップ抵抗	R647		
	RD258220	CHIP RESISTOR 220K Ω 0.1W	チップ抵抗	R231,232,234,236,244, 362,369,372,388,609,	299,359, 245,656	
	RD258470	CHIP RESISTOR 470K Ω 0.1W	チップ抵抗	R222,223		
+	VH256800	CHIP RESISTOR 1K Ω	チップ抵抗	R266,269		
+	Vi198600	CHIP METAL FILM RESISTOR 33K Ω 1/16W	チップ金被抵抗	R357,364,367,374		
	HV453100	FLAME PROOF RESISTOR 1 Ω 1/4W	不燃化カーボン抵抗	R356,365,366,375		
	HV753470	FLAME PROOF RESISTOR 4.7 Ω 1/4W	不燃化カーボン抵抗	R729		
				R640,641		

*New Parts (新規部品)

ランク : Japan only

Ref. NO.	PART NO.	Description	部品名		Remarks	Markets	ランク
	HV455560	FLAME PROOF RESISTOR	560Ω	1/4W	不燃化カーボン抵抗	R620,628	
	HV454100	FLAME PROOF RESISTOR	10Ω	1/4W	不燃化カーボン抵抗	R386,389,396,397,605	
	HV455100	FLAME PROOF RESISTOR	100Ω	1/4W	不燃化カーボン抵抗	R744	A,B,G
	HV453330	FLAME PROOF RESISTOR	3.3Ω	1/4W	不燃化カーボン抵抗	R732	
	Vi435900	METAL OXIDE RESISTOR	0.1Ω	1W	酸化金属被膜抵抗	R632,633	
	HL324820	METAL OXIDE RESISTOR	82Ω	2W	酸化金属被膜抵抗	R624,625	
	Vi294900	METAL OXIDE RESISTOR	0.15Ω	2W	酸化金属被膜抵抗	R614-617	
	XB247301	IC	UPC4570HA		IC	IC202,204,206,207,211,212,217,218,224	
	XE472001	IC	UPC4072HA		IC	IC203	
	XF291A00	IC	UPC4570G2		IC	IC201	
	XF971A00	IC	UPC4574C		IC	IC214	
	XE470001	IC	M51132L		IC	IC208,210,213,216	
	iG077400	IC	NJM4556S		IC	IC209,	
	iG102700	IC	UPC1188H		IC	IC219-223	
	XF612A00	IC	AN79M05F		IC	IC226	
	XB467001	IC	AN79M15F		IC	IC227	
	XG732A00	IC	LC7821N		IC	IC225	
	XG502A00	IC	LA7213		IC	IC702	
	XB736001	IC	UPD4053BG		IC	IC205	
	iG142220	IC	UPD74HCU04C		IC	IC701	
	iG055100	IC	TC4053BP		IC	IC215,704	
	XD132001	IC	M50455-060SP		IC	IC703	
	Vi550300	PUSH SWITCH	ESB82104V		プッシュSW	SW204	
	VH731800	SLIDE SWITCH	SSSF12		スライドSW	SW201	
	VH731900	SLIDE SWITCH	SSSF14		スライドSW	SW202,203	
	VF541200	SLIDE SWITCH	SSSF11		スライドSW	SW701	R
	KB002020	FUSE	4A 125V		ヒューズ	F201	U,C
	KB000380	FUSE	4A 250V		ヒューズ	F201	J,R
	KB000680	FUSE	1.25A 250V		ヒューズ	F201	A,G,B
	KB000350	FUSE	2A 250V		ヒューズ	F203	R
	LA002140	LAPPING TERMINAL	2P I-102NA		ラッピング端子	TE203	
	LA002140	LAPPING TERMINAL	2P I-102NA		ラッピング端子	TE204	R
	LA002320	LAPPING TERMINAL	3P I-753NA		ラッピング端子	TE201	
	LA003870	LAPPING TERMINAL	2P L-102NE		ラッピング端子	TE205	A,G,B
	Vi217200	PIN JACK	T6180-AAAF		ピンジャック 2P	PJ701	
	VH733900	PIN JACK	T6419-AABB		ピンジャック 2P	PJ204	
	Vi205900	PIN JACK			ピンジャック 2P	PJ203	
	VJ133600	PIN JACK			ピンジャック	PJ201,202	
	Vi185800	PHONES JACK	HLJ2317		ホーンジャック	JK203	
	Vi185900	MICROPHONE JACK	HLJ0347		2連マイクジャック	JK201	
	LB608170	AC OUTLET	M7032D		ACソケット	JK202	J,U,C,R
	Vi234500	CONNECTOR	4P M1821-B		2連DNコネクター	JK701	
	LB918040	BASE PIN	XH 4P TE		ベースツキポスト	CB201,208,212	
	LB918020	BASE PIN	XH 2P TE		ベースツキポスト	CB203	
	LB932040	BASE PIN	VH 4P TE		ベースポスト	CB211	
	VD004600	BASE PIN	PH 3P TE		ベースピン	CB204	
	VD005000	BASE PIN	PH 7P TE		ベースピン	CB206	
	VD005100	BASE PIN	PH 8P TE		ベースピン	CB205,701	
	Vi377500	BASE PIN	MQ 5P TE		MQ ベースピン	CB209	

*New Parts (新規部品)

ランク : Japan only

Ref. NO.	PART NO.	Description	部 品 名		Remarks	Markets	ランク
+	Vi378000	BASE PIN	MQ	10P TE	MQ ベースピン	CB210	
	VD980900	QUARTZ CRYSTAL	14.3181W	AD0978CFA	水晶振動子	XL701	J,U,C,R
	VF066800	QUARTZ CRYSTAL	17.7344W	AT-49	水晶振動子	XL701	A,G,B
+	VH732000	POTENTIOMETER	A10KΩ	RK11K112	ロータリーV R	VR206-208	
+	Vi233800	POTENTIOMETER	A10KΩ	RK14K12B	二連ロータリーV R	VR202,204	
+	VH746600	POTENTIOMETER	B10KΩ	RK09K12A	二連ロータリーV R	VR205	
+	Vi233700	POTENTIOMETER	50KΩ	RK14K122	二連ロータリーV R	VR203	
+	Vi809100	POTENTIOMETER	A10KΩ	RK14K12B	二連ロータリーV R	VR201	
	iA093370	TRANSISTOR	2SA933S	Q,R	トランジスタ	Q217,220,221,226,227,	702,703
	iC174070	TRANSISTOR	2SC1740S	R,S	トランジスタ	Q222,224,229,701,	704-706
	iC174070	TRANSISTOR	2SC1740S	R,S	トランジスタ	Q710	A,B,G
	iC1815C0	TRANSISTOR	2SC1815	Y	トランジスタ	Q707,708	
	VC502100	TRANSISTOR	2SD1915	S,T	トランジスタ	Q201-216,218,219	
	VE170300	FET	2SK442		F E T	Q709	
	VD678500	DIGITAL TRANSISTOR	DTA114ES		デジタルトランジスタ	Q225	
	VD678700	DIGITAL TRANSISTOR	DTC114ES		デジタルトランジスタ	Q228	
	iF004000	DIODE	1S133		ダイオード	D201,204,205,207,	701-704
	VE367900	DIODE BRIDGE	DF02M	1A 200V	D i ブリッジ	D202	
	VG437700	ZENER DIODE	MTZJ5.6B	5.6V	ツェナーダイオード	D206	
+	VG439500	ZENER DIODE	MTZJ10B	10V	ツェナーダイオード	D203	
	LB201880	FUSE HOLDER PIN	PC-FH1		ヒューズホルダピン		
+	VB698800	CONNECTOR ASSY	300MM	6P	PHコネクタASSY		
+	VB705000	CONNECTOR ASSY	120MM	10P	PHコネクタASSY		
	VB721100	CONNECTOR ASSY	400MM	10P	PHコネクタASSY		
	BA092970	RADIATOR			放熱器		
+	Vi233500	SHEILD COVER			シールドカバー		
	RD256150	CHIP RESISTOR	1.5KΩ	0.1W	チップ抵抗	R242,247	
	RD256160	CHIP RESISTOR	1.6KΩ	0.1W	チップ抵抗	R300	
	RD256180	CHIP RESISTOR	1.8KΩ	0.1W	チップ抵抗	R257,276,281,288,297	
	RD256300	CHIP RESISTOR	3KΩ	0.1W	チップ抵抗	R307,308,311,312	
	Vi184700	OPERATION CIRCUIT BOARD			オペレーションシート		U,C
	VJ191200	OPERATION CIRCUIT BOARD			オペレーションシート		J
	VJ070300	OPERATION CIRCUIT BOARD			オペレーションシート		R,A,B,G
	UA254220	MYLAR FILM CAP	0.022μF	50V	マイラーコン	C61-63,66,67	
	UA254270	MYLAR FILM CAP	0.027μF	50V	マイラーコン	C17	
	UA254100	MYLAR FILM CAP	0.01μF	50V	マイラーコン	C60,64,65,68,69	
	FG144330	CERAMIC CAP	0.033μF	50V	セラコン	C14	
	FZ005880	CERAMIC CAP	0.1μF	25V	積層セラコン	C6	
+	VH531900	CHIP CERAMIC CAP	100PF	50V	チップ積層セラコン	C4,102,103,106,107,117,124	
+	Vi227000	CHIP CERAMIC CAP	120PF	50V	チップセラコン	C87-91,93-96,98,	143-151,
						157,160-163	
+	Vi227600	CHIP CERAMIC CAP	220PF	50V	チップセラコン	C59,125-128	
+	VH058000	CHIP CERAMIC CAP	470PF	50V	チップ積層セラコン	C72,73	
	UT454100	POLYPROPYLEN FILM CAP	0.01μF	100V	PPコン	C172	

※New Parts (新規部品)

ランク : Japan only

Ref. NO.	PART NO.	Description			部 品 名	Remarks	Markets	ランク
	UT452470	POLYPROPYLEN FILM CAP	470pF	100V	PPコン	C70,71		03
*	Vi228800	CHIP CERAMIC CAP	680PF	50V	チップセラコン	C29,30		
*	Vi229300	CHIP CERAMIC CAP	1000PF	50V	積層チップセラコン	C118,123		
*	Vi230900	CHIP CERAMIC CAP	4700PF	50V	積層チップセラコン	C16		
*	Vi231100	CHIP CERAMIC CAP	5800PF	50V	積層チップセラコン	C23		
*	Vi231300	CHIP CERAMIC CAP	6800PF	50V	積層チップセラコン	C39,40		
*	Vi231700	CHIP CERAMIC CAP	0.01μF	50V	積層チップセラコン	C57,58,167		
*	Vi229900	CHIP CERAMIC CAP	1800PF	50V	積層チップセラコン	C101,104		
*	Vi230300	CHIP CERAMIC CAP	2700PF	50V	積層チップセラコン	C97,99		
*	Vi230500	CHIP CERAMIC CAP	3300PF	50V	積層チップセラコン	C105,108		
*	VD499400	CHIP CERAMIC CAP	0.1μF	25V	チップ積層セラコン	C3,5,8,25-28,76-78,120	.121, 131-136,139-142,158,	152-156
	VG286800	ELECTROLYTIC CAP	100μF	10V	ケミコン	C137,138,159		
	VG287200	ELECTROLYTIC CAP	10μF	16V	ケミコン	C54,92,130,168,170,171		
	VG287300	ELECTROLYTIC CAP	22μF	16V	ケミコン	C18		
	VG287400	ELECTROLYTIC CAP	33μF	16V	ケミコン	C20,21,24,41,51,100,	109-112,	
	VG287500	ELECTROLYTIC CAP	47μF	16V	ケミコン	C42,49,119,122,129		
	VG287600	ELECTROLYTIC CAP	100μF	16V	ケミコン	C19,55		
	VG290500	ELECTROLYTIC CAP	1μF	50V	ケミコン	C11,12,15,22,56,	113-116	
	VG290800	ELECTROLYTIC CAP	4.7μF	50V	ケミコン	C35-38,45,46,52,53		
	VG286600	ELECTROLYTIC CAP	1000μF	6.3V	ケミコン	C9		
	VG290100	ELECTROLYTIC CAP	0.22μF	50V	ケミコン	C43,44,47,48		
	VG290200	ELECTROLYTIC CAP	0.33μF	50V	ケミコン	C10,31,33		
	VG290300	ELECTROLYTIC CAP	0.47μF	50V	ケミコン	C50		
	VE832800	ELECTROLYTIC CAP	0.047F	5.5V	スーパーキャパシタ	C1		
	UH157470	ELECTROLYTIC CAP	47μF	35V	ケミコン	C185		
	UJ157330	ELECTROLYTIC CAP	33μF	35V	ケミコン	C164		
	UW565150	ELECTROLYTIC CAP	0.15μF	50V	ケミコン	C32,34		
	UH166100	ELECTROLYTIC CAP	1μF	50V	ケミコン	C2		
	GD900680	COIL	SM-5752	10x5	空芯コイル	L2-6		
	VC362000	COIL	EL0606	1mH	コイル	L1		
	RD250000	CHIP RESISTOR	0Ω	0.1W	チップ抵抗	J1-25		
*	RD253220	CHIP RESISTOR	2.2Ω	0.1W	チップ抵抗	R102-104,168		
*	RD254100	CHIP RESISTOR	10Ω	0.1W	チップ抵抗	R175,176		
	RD254330	CHIP RESISTOR	33Ω	0.1W	チップ抵抗	R27,29,31,33,35,38,41,	44	
	RD254470	CHIP RESISTOR	47Ω	0.1W	チップ抵抗	R26,28,30,32,34,37,40,	43	
*	RD254820	CHIP RESISTOR	82Ω	0.1W	チップ抵抗	R36,39,42,45		
*	RD255100	CHIP RESISTOR	100Ω	0.1W	チップ抵抗	R154,155,161,162		
	RD255180	CHIP RESISTOR	180Ω	0.1W	チップ抵抗	R155		
	RD255220	CHIP RESISTOR	220Ω	0.1W	チップ抵抗	R76		
*	RD255470	CHIP RESISTOR	470Ω	0.1W	チップ抵抗	R1-3,12-15,17-21,167		
*	RD255560	CHIP RESISTOR	560Ω	0.1W	チップ抵抗	R7		
	RD256100	CHIP RESISTOR	1KΩ	0.1W	チップ抵抗	R9,73,156		
	RD256220	CHIP RESISTOR	2.2KΩ	0.1W	チップ抵抗	R117,119,121,123,125,	128	
	RD256330	CHIP RESISTOR	3.3KΩ	0.1W	チップ抵抗	R54		
*	RD256390	CHIP RESISTOR	3.9KΩ	0.1W	チップ抵抗	R8,158		
	RD256560	CHIP RESISTOR	5.6KΩ	0.1W	チップ抵抗	R58		
*	RD256620	CHIP RESISTOR	6.2KΩ	0.1W	チップ抵抗	R81		
*	RD256680	CHIP RESISTOR	6.8KΩ	0.1W	チップ抵抗	R143-146,149-152		

*New Parts (新規部品)

ランク : Japan only

Ref. NO.	PART NO.	Description	部 品 名		Remarks	Markets	ランク
*	RD258750	CHIP RESISTOR	7.5KΩ	0.1W	チップ抵抗	R84,85	
*	RD258820	CHIP RESISTOR	8.2KΩ	0.1W	チップ抵抗	R140,142,147,148	
*	RD258910	CHIP RESISTOR	9.1KΩ	0.1W	チップ抵抗	R163-166	
*	RD257100	CHIP RESISTOR	10KΩ	0.1W	チップ抵抗	R5,59,114,116,118,120,133,169,171,172,174,	122,132,178
*	RD257150	CHIP RESISTOR	15KΩ	0.1W	チップ抵抗	R60,61,80	
*	RD257160	CHIP RESISTOR	16KΩ	0.1W	チップ抵抗	R124,129,131,134,135,141	138,139,
	RD257220	CHIP RESISTOR	22KΩ	0.1W	チップ抵抗	R75,77	
	RD257270	CHIP RESISTOR	27KΩ	0.1W	チップ抵抗	R56,153,160	
	RD257470	CHIP RESISTOR	47KΩ	0.1W	チップ抵抗	R4,52,62,63,78	
	RD258100	CHIP RESISTOR	100KΩ	0.1W	チップ抵抗	R6,10,11,22-25,57,79,115,127,130	112,113,
*	RD258270	CHIP RESISTOR	270KΩ	0.1W	チップ抵抗	R51	
	RD258560	CHIP RESISTOR	560KΩ	0.1W	チップ抵抗	R170,173	
	RD259100	CHIP RESISTOR	1MΩ	0.1W	チップ抵抗	R16,74,177	
	HV753100	FLAME PROOF RESISTOR	1Ω	1/4W	不燃化カーボン抵抗	R201	
	HV454100	FLAME PROOF RESISTOR	10Ω	1/4W	不燃化カーボン抵抗	R82,84-87	
	HL314680	METAL OXIDE RESISTOR	68Ω	1W	酸化金属被膜抵抗	R157,159	
	XB247301	IC	UPC4570HA		IC	IC9-13	
	XB248001	IC	M5238L		IC	IC14,16	
	XD386001	IC	LA2730		IC	IC5	
	XA507001	IC	AN78N05		IC	IC32	
	XF982A00	IC	AN78L12		IC	IC7	
*	XG780A00	IC	AN79N05		IC	IC33	
	XB449A00	IC	AN7815F		IC	IC35	
	XB646001	IC	AN78M05F		IC	IC34	
	XG497A00	IC	LA2770		IC	IC6	
	iG105900	IC	UPD4053BC		IC	IC30,31	
*	XE520A00	IC	UPD74HC00G-T1		IC	IC25	
*	XG535A00	IC	UPD74HC04G		IC	IC20	
*	XE821A00	IC	UPD74HC74G		IC	IC21,22	
*	XG536A00	IC	UPD74HC175G		IC	IC24	
*	XG534A00	IC	UPD74HC393G		IC	IC23	
*	iG001720	IC	TC4069UBP		IC	IC8	
*	XG700A00	IC	HD63B01YORL37P		IC	IC27	
*	XG701A00	IC	M50747-B87		IC	IC2	J,R,A,B,G
*	XG701B00	IC	M50747-C36		IC	IC2	U,C
*	XC628A00	IC	TC51832PL-10		IC	IC29	
*	iG081900	IC	HA17408P		IC	IC1	
*	XG499A00	IC	AK9201		IC	IC17	
	XD898001	IC	PCM56P-L		IC	IC18,19	
	XE449A00	IC	YN3413		IC	IC28	
	XE862001	IC	YN3422		IC	IC26	
	VF926500	RECEIVE UNIT	GP1U501X		リモコン受光ユニット	U1	
	VE327300	PUSH SWITCH			プッシュSW	SW1-17	
	Vi032300	ROTARY ENCODOR	EC16B40B		ロータリーエンコーダ	SW18	
*	KB003160	FUSE	3A	250V	ヒューズ	F1-5	J,U,C
*	KB000760	FUSE	3.15A	250V	ヒューズ	F1-5	R,A,B,G

*New Parts (新規部品)

ランク : Japan only

Ref. NO.	PART NO.	Description	部 品 名	Remarks	Markets	ランク
*	Vi234400	PIN JACK	T8385-AACB 6P	ピンジャック	PJ1	
*	Vi072400	TERMINAL	T6448-B 2P	ターミナル	TE1	
*	Vi072500	TERMINAL	T6466 4P	ターミナル	TE2,3	
*	Vi378300	CONNECTOR SOCKET	MQ 5P	MQコネクタソケット	CB15	
*	Vi378800	CONNECTOR SOCKET	MQ 10P	MQコネクタソケット	CB19	
	VD004600	BASE PIN	PH 3P TE	ベースピン	CB16	
	VD004800	BASE PIN	PH 5P TE	ベースピン	CB13	
	VD005200	BASE PIN	PH 9P TE	ベースピン	CB12	
	VD005300	BASE PIN	PH 10P TE	ベースピン	CB20	
*	Vi814900	FILTER		LCフィルター	FI3-6	
*	Vi815000	FILTER		LCフィルター	FI1,2	
*	VB657100	CERAMIC RESONATER	8MHz CST8MT	セラミック共振子	XL1	
*	Vi231800	CERAMIC RESONATER	16M CST16M	セラミック共振子	XL2	
	iA093370	TRANSISTOR	2SA933S Q,R	トランジスタ	Q7,10,16	
	iC174070	TRANSISTOR	2SC1740S R,S	トランジスタ	Q1,5,6,8	
	VC502100	TRANSISTOR	2SD1915 S,T	トランジスタ	Q12-15	
	iG031100	TRANSISTOR ARRAY	M54516	トランジスタアレイ	IC3	
	VD938100	DIGITAL TRANSISTOR ARRAY	DT5A143E	デジタルアレイ	IC4	
	VH964100	DIGITAL TRANSISTOR	DTA143ES	デジタルトランジスタ	Q2-4	
	VD678700	DIGITAL TRANSISTOR	DTC114ES	デジタルトランジスタ	Q11	
	iF004600	DIODE	ISS133	ダイオード	D2,3,28-32,37	
	VH770800	DIODE	1SR139-100	ダイオード	D1	
	VD450400	DIODE ARRAY	1SS233 0.3Ax2	ダイオードアレイ	D35	
	VD450500	DIODE ARRAY	1SS235 0.3Ax2	ダイオードアレイ	D36	
	Vi013600	LED	SLR-34VC3H3	LED	D16-19,27	
	VF402500	LED	SLR-34DC3H3	LED	D4-15,20-26	
*	Vi217600	LED DISPLAY	GL6S228M	LEDディスプレイ	D33	
	LB201060	FUSE HOLDER PIN	YSH403T	ヒューズホルダピン		
*	VB716000	CONNECTOR ASSY	400MM	PHコネクタASSY		
	BB071360	TERMINAL,SCR	8.3x13	ネジ端子		
*	Vi233400	SPACER	2J/12	スペーサ		
*	Vi435400	GROUND PLATE		アースプレート		
	RD256150	CHIP RESISTOR	1.5KΩ 0.1W	チップ抵抗	R58	
	RD256270	CHIP RESISTOR	2.7KΩ 0.1W	チップ抵抗	R185,187	
	RD256680	CHIP RESISTOR	6.8KΩ 0.1W	チップ抵抗	R186,188	
	RD257100	CHIP RESISTOR	10KΩ 0.1W	チップ抵抗	R189,192,195,198	
	RD257110	CHIP RESISTOR	11KΩ 0.1W	チップ抵抗	R139,141	
	RD257150	CHIP RESISTOR	15KΩ 0.1W	チップ抵抗	R132,133	
	RD257160	CHIP RESISTOR	16KΩ 0.1W	チップ抵抗	R191,194,197,200	
	RD257240	CHIP RESISTOR	24KΩ 0.1W	チップ抵抗	R131,134,135,138	
	RD257330	CHIP RESISTOR	33KΩ 0.1W	チップ抵抗	R190,193,196,199	
	VH531900	CHIP CERAMIC CAP	100PF 50V	チップセラコン	C173-176	
	Vi229500	CHIP CERAMIC CAP	1200PF 50V	チップセラコン	C101,104	
	Vi230100	CHIP CERAMIC CAP	2200PF 50V	チップセラコン	C105,108	
	Vi842400	ELECTROLYTIC CAP	33μF 16V	ケミコン	C177	
	XF971A00	IC	uPC4574C	IC	IC36	

*New Parts (新規部品)

ランク : Japan only

Ref. NO.	PART NO.	Description	部 品 名	Remarks	Markets	ランク
*	VJ341200	FUSE CIRCUIT BOARD		ヒューズシート	J,R	
*	VJ341300	FUSE CIRCUIT BOARD		ヒューズシート	A,B,G	
*	VJ355200	FUSE CIRCUIT BOARD		ヒューズシート	U,C	
*	Vi234100	DIODE BRIDGE	RBV-602	ダイオードブリッジ	D38	
*	KB001490	FUSE	10A 250V	ヒューズ	F6,7	J,R
	VD370900	FUSE	10A 250V	ヒューズ	F6,7	U,C
	KB000780	FUSE	T5A 250V	ヒューズ	F6,7	A,B,G
	LB201880	FUSE HOLDER PIN		ヒューズホルダピン		

*New Parts (新規部品)

ランク : Japan only

EXPLODED VIEW

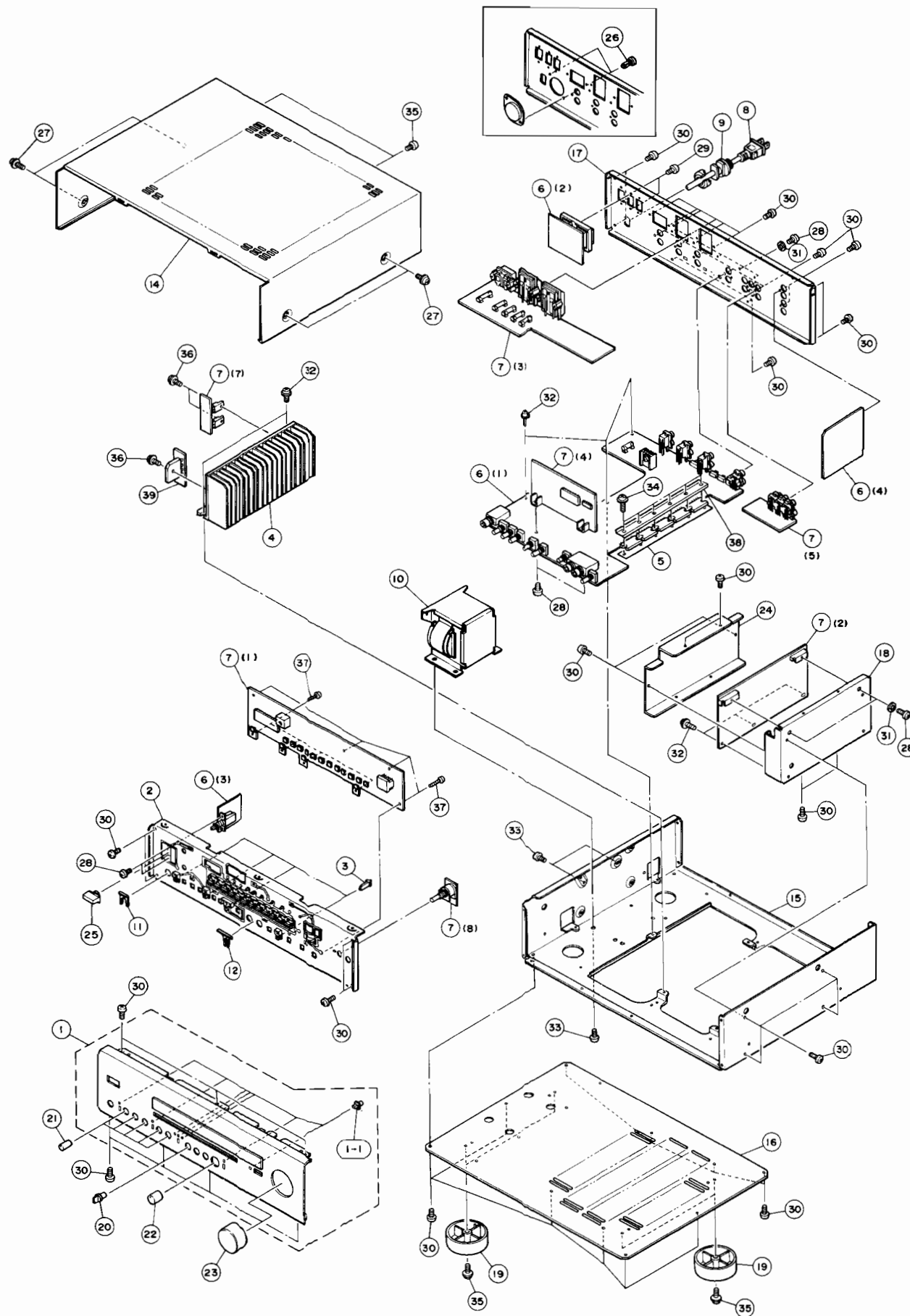

MECHANICAL PARTS Note) φ : Diameter

Ref. NO.	PART NO.	Description	部品名	Remarks	Markets	ランク
01	Vi183700	FRONT PANEL UNIT	フロントパネルユニット	BL	J	
01	Vi183800	FRONT PANEL UNIT	フロントパネルユニット	BL	UCRABG	
01	Vi183900	FRONT PANEL UNIT	フロントパネルユニット	T	J	
01	Vi184000	FRONT PANEL UNIT	フロントパネルユニット	T	UCRABG	
01-1	VH897700	LENS	レンズ			
02	NX805530	SUB CHASSIS	サブシャーシ	BL		
02	NX805340	SUB CHASSIS	サブシャーシ	T		
03	VH920100	BUTTON	ボタン	BL		
03	VH920200	BUTTON	ボタン	T		
04	VH955700	RADIATOR	ラジエータ			
05	Vi202100	SHEET	シート			
06	Vi608800	EFFECT CIRCUIT BOARD	エフェクトシート		J	
06	Vi184300	EFFECT CIRCUIT BOARD	エフェクトシート		U,C	
06	Vi184600	EFFECT CIRCUIT BOARD	エフェクトシート		A,B,G	
06	Vi184500	EFFECT CIRCUIT BOARD	エフェクトシート		R	
07	Vi184700	OPERATION CIRCUIT BOARD	オペレーションシート		U,C	
07	VJ191200	OPERATION CIRCUIT BOARD	オペレーションシート		J	
07	VJ070300	OPERATION CIRCUIT BOARD	オペレーションシート		R,A,B,G	
08	VC614400	POWER CORD	電源コード	12A 2M	J	△
08	MG002220	POWER CORD	電源コード	10A SPT-2	U,C	△
08	VE371000	POWER CORD	電源コード	6A 2M	R	△
08	MG002310	POWER CORD	電源コード	7.5A 250V	A	△
08	MG002330	POWER CORD	電源コード	6A 250V	B	△
08	MG002320	POWER CORD	電源コード	2.5A 250V	G	△
09	CB620200	CORD STOPPER	コードストッパー	CM-22C	U,C	
09	CB620190	CORD STOPPER	コードストッパー	CM-22B	R,A,B,G	
10	XG786A00	POWER TRANSFORMER	電源トランス		J	△
10	XG787B00	POWER TRANSFORMER	電源トランス		U	△
10	XH154B00	POWER TRANSFORMER	電源トランス		C	△
10	XG788A00	POWER TRANSFORMER ASS'Y	電源トランスASS'Y		R	△
	LB201480	VOLTAGE SELECTOR	電圧切替器		R	△
10	XG789A00	POWER TRANSFORMER	電源トランス		A,B	△
10	XG790B00	POWER TRANSFORMER	電源トランス		G	△
11	LB301910	METAL FITTINGS,U-TYPE	U字金具	HLJ0999-01-480		
12	LB302220	ANGLE,BRACKET	T字金具	HLJ0999-01-490		
14	VH953600	TOP COVER	トップカバー	BL		
14	VH953700	TOP COVER	トップカバー	T		
15	VH953800	CHASSIS	シャーシ			
16	VH953900	BOTTOM COVER	ボトムカバー			
17	VH958400	REAR PANEL	リヤパネル		J	
17	VH958500	REAR PANEL	リヤパネル		U,C	
17	VH958700	REAR PANEL	リヤパネル		R	
17	VH958800	REAR PANEL	リヤパネル		A,B	
17	VH958900	REAR PANEL	リヤパネル		G	
18	VH956400	SHEILD BOX	シールドボックス			
19	Vi615200	LEG	レッグ		J	
19	CB660950	LEG	レッグ	BL	UCRABG	
19	Vi175700	LEG	レッグ	T	UCRABG	
20	VH888800	KNOB	ノブ	BL		
20	VH888900	KNOB	ノブ	T		

*New Parts (新規部品)

ランク : Japan only

Ref. NO.	PART NO.	Description	部 品 名		Remarks	Markets	ランク
* 21	VH889000	KNOB	D9	ノブ	BL		
* 21	VH889100	KNOB	D9	ノブ	T		
* 22	VH889200	KNOB	D14	ノブ	BL		
* 22	VH889300	KNOB	D14	ノブ	T		
* 23	VH953300	KNOB	D40	ノブ	BL		
* 23	VH953400	KNOB	D40	ノブ	T		
* 24	V1435300	SHEILD PLATE		シールドプレート			
* 25	VH841900	BUTTON	10/25	ボタン	BL		
* 25	VH842000	BUTTON	10/25	ボタン	T		
26	CB068880	PLASTIC RIVET	#1027	プラスチックリベット		R	
27	EK365040	BW HEAD SCREW	4x8-10	FCM3-BL	BWヘッド小ネジ	BL	
27	EX601150	BW HEAD S-TYTE SCREW	4X8-10	FCM3-BL	BWヘッドSタイトネジ	T	
28	ED330066	BINDING HEAD SCREW	3x6	FCM3-BL	バインド小ネジ		
29	EX600310	BINDING HEAD SCREW	3x8	FCRM3-BL	バインドPタイト		J,U,C,R
30	EM301010	BIND HEAD BONDING SCREW	3x8	FCM3-BL	ボンディングBタイト		
31	EV413036	TOOTHED LOCK WASHER	φ 3	FCM3-BL	歯付座金		
32	EX600240	BW HEAD TAPPING SCREW	3x8	FCM3-BL	BWヘッドタッピングネジ		
33	E1340086	BINDING HEAD SCREW	4x8	FCM3-BL	バインドタッピングネジ		
34	EX601090	BW HEAD TAPPING SCREW	3x12	FCM3-BL	BWヘッドタッピングネジ		
35	E1330086	BINDING HEAD SCREW	3x8	FCRM3-BL	バインドタッピングネジ		
36	EX600920	CUP SCREW B-TYTE	3x12	FCM3-BL	カップBタイトネジ		
37	EJ326086	PAN HEAD TAPPING SCREW	2.6x8	ZMC3-BL	ナベタッピングネジ	BL	
	CB069251	BINDING TIE	BK-1		束線止め	PACK	
38	V1924900	FRAME IC			フレームIC		
* 39	VJ341200	FUSE CIRCUIT BOARD			ヒューズシート		J,R
* 39	VJ341300	FUSE CIRCUIT BOARD			ヒューズシート		A,B,G
* 39	VJ355200	FUSE CIRCUIT BOARD			ヒューズシート		U,C
		ACCESSORIES			付属品		
* 39	V1054000	REMOTE CONTROL TRANSMITTER			トランスミッター		
* 39	CX611300	LID			電池ケース		
		DRY CELL	UM-4, R03, AAA		マンガン電池		
* 39	V1182200	ACCESSORIES ASS'Y			付属品ASSY		J
	VJ069800	ACCESSORIES ASS'Y			付属品ASSY		UCRABG
* 39	VJ068900	PIN CORD			PPコード OFC		J
* 39	VJ068800	PIN CORD			PPコードキイ OFC		J
* 39	VJ069000	S CONNECTION CABLE			S接続ケーブル		J
	M1088790	PIN CORD	1M		PPコード アカ, シロ		UCRABG
	VB308200	PIN CORD	2M		PPコード キイ		UCRABG

*New Parts (新規部品)

ランク : Japan only

REMOTE CONTROL TRANSMITTER

EXPLODED VIEW

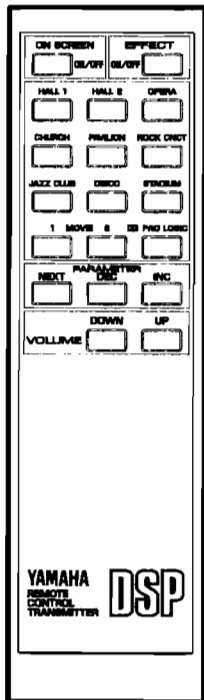
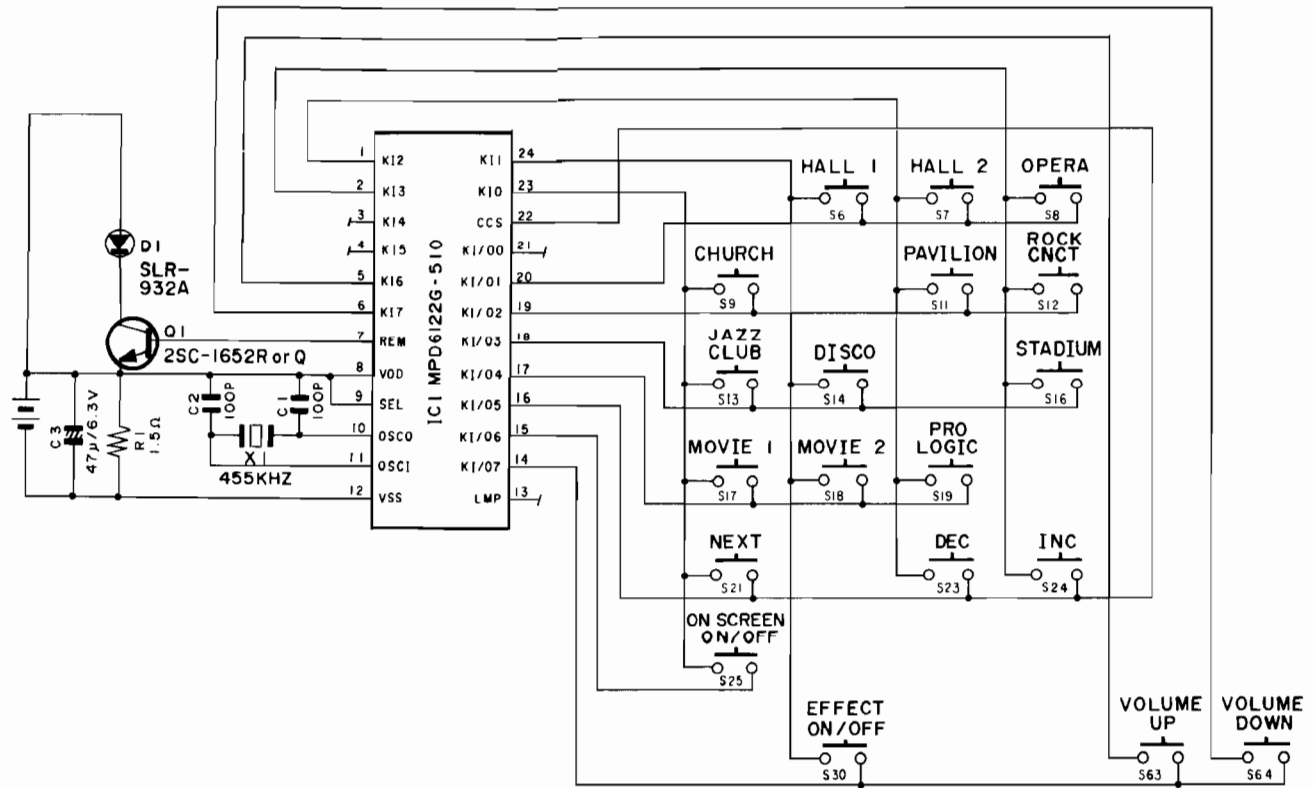

CUSTOM CODE

C0 C1 C2 C3 C4 C5 C6 C7
1 0 1 1 1 1 1 0

KEY No.	DATA CODE								FUNCTION
	D0	D1	D2	D3	D4	D5	D6	D7	
6	1	0	1	0	0	0	0	0	HALL 1
7	0	1	1	0	0	0	0	0	HALL 2
8	1	1	1	0	0	0	0	0	OPERA
9	0	0	0	1	0	0	0	0	CHURCH
11	0	1	0	1	0	0	0	0	PAVILION
12	1	1	0	1	0	0	0	0	ROCK CNCT
13	0	0	1	1	0	0	0	0	JAZZ CLUB
14	1	0	1	1	0	0	0	0	DISCO
16	1	1	1	1	0	0	0	0	STADIUM
17	0	0	0	0	1	0	0	0	MOVIE 1
18	1	0	0	0	1	0	0	0	MOVIE 2
19	0	1	0	0	1	0	0	0	<input checked="" type="checkbox"/> PRO LOGIC
21	0	0	1	0	1	0	0	0	PARAMETER NEXT
23	0	1	1	0	1	0	0	0	PARAMETER DEC
24	1	1	1	0	1	0	0	0	PARAMETER INC
25	0	0	0	1	1	0	0	0	ON SCREEN ON/OFF
30	1	0	1	1	1	0	0	0	EFFECT ON/OFF
63	0	1	1	1	1	0	1	0	VOLUME UP
64	1	1	1	1	1	0	1	0	VOLUME DOWN

Parts List for Carbon Resistors

Value	1/4W Type Part No.	1/6W Type Part No.	Value	1/4W Type Part No.	1/6W Type Part No.
1.0 Ω	HJ35 3100	HF853100	12 KΩ	HJ35 7120	HF85 7120
1.8 Ω	HJ35 3180	*	15 KΩ	HJ35 7150	HF85 7150
2.2 Ω	HJ35 3220	HF853220	18 KΩ	HJ35 7180	HF85 7180
3.3 Ω	HJ35 3330	HF853330	22 KΩ	HJ35 7220	HF85 7220
4.7 Ω	HJ35 3470	HF853470	27 KΩ	HJ35 7270	HF85 7270
5.6 Ω	HJ35 3560	HF853560	33 KΩ	HJ35 7330	HF85 7330
10 Ω	HJ35 4100	HF85 4100	39 KΩ	HJ35 7390	HF85 7390
15 Ω	HJ35 4150	HF85 4150	47 KΩ	HJ35 7470	HF85 7470
22 Ω	HJ35 4220	HF85 4220	56 KΩ	HJ35 7560	HF85 7560
27 Ω	HJ35 4270	HF85 4270	68 KΩ	HJ35 7680	HF85 7680
33 Ω	HJ35 4330	HF85 4330	82 KΩ	HJ35 7820	HF85 7820
39 Ω	HJ35 4390	HF85 4390	91 KΩ	HJ35 7910	HF85 7910
47 Ω	HJ35 4470	HF85 4470	100 KΩ	HJ35 8100	HF85 8100
56 Ω	HJ35 4560	HF85 4560	120 KΩ	HJ35 8120	HF85 8120
68 Ω	HJ35 4680	HF85 4680	150 KΩ	HJ35 8150	HF85 8150
82 Ω	HJ35 4820	HF85 4820	180 KΩ	HJ35 8180	HF85 8180
100 Ω	HJ35 5100	HF85 5100	220 KΩ	HJ35 8220	HF85 8220
110 Ω	HJ35 5110	HF85 5110	270 KΩ	HJ35 8270	HF85 8270
120 Ω	HJ35 5120	HF85 5120	330 KΩ	HJ35 8330	HF85 8330
150 Ω	HJ35 5150	HF85 5150	390 KΩ	HJ35 8390	HF85 8390
160 Ω	HJ35 5160	*	470 KΩ	HJ35 8470	HF85 8470
180 Ω	HJ35 5180	HF85 5180	560 KΩ	HJ35 8560	HF85 8560
220 Ω	HJ35 5220	HF85 5220	680 KΩ	HJ35 8680	HF85 8680
270 Ω	HJ35 5270	HF85 5270	820 KΩ	HJ35 8820	HF85 8820
330 Ω	HJ35 5330	HF85 5330	1.0 MΩ	HJ35 9100	HF85 9100
390 Ω	HJ35 5390	HF85 5390	1.2 MΩ	HJ35 9120	*
470 Ω	HJ35 5470	HF85 5470	1.5 MΩ	HJ35 9150	HF85 9150
510 Ω	*	HF85 5510	1.8 MΩ	HJ35 9180	HF85 9180
560 Ω	HJ35 5560	HF85 5560	2.2 MΩ	HJ35 9220	HF85 9220
680 Ω	HJ35 5680	HF85 5680	3.3 MΩ	HJ35 9330	HF85 9330
820 Ω	HJ35 5820	HF85 5820	3.9 MΩ	HJ35 9390	*
910 Ω	HJ35 5910	HF85 5910	4.7 MΩ	HJ35 9470	HF85 9470
1.0 KΩ	HJ35 6100	HF85 6100			
1.2 KΩ	HJ35 6120	HF85 6120			
1.5 KΩ	HJ35 6150	HF85 6150			
1.8 KΩ	HJ35 6180	HF85 6180			
2.0 KΩ	HJ35 6200	HF85 6200			
2.2 KΩ	HJ35 6220	HF85 6220			
2.4 KΩ	HJ35 6240	HF85 6240			
2.7 KΩ	HJ35 6270	HF85 6270			
3.0 KΩ	HJ35 6300	HF85 6300			
3.3 KΩ	HJ35 6330	HF85 6330			
3.6 KΩ	HJ35 6360	HF85 6360			
3.9 KΩ	HJ35 6390	HF85 6390			
4.7 KΩ	HJ35 6470	HF85 6470			
5.1 KΩ	HJ35 6510	HF85 6510			
5.6 KΩ	HJ35 6560	HF85 6560			
6.8 KΩ	HJ35 6680	HF85 6680			
8.2 KΩ	HJ35 6820	HF85 6820			
9.1 KΩ	HJ35 6910	HF85 6910			
10 KΩ	HJ35 7100	HF85 7100			

